



ЛИНЕЙНЫЕ ДВИГАТЕЛИ SM 25

Архангельск (8182)63-90-72
Астана +7(7172)727-132
Белгород (4722)40-23-64
Брянск (4832)59-03-52
Владивосток (423)249-28-31
Волгоград (844)278-03-48
Вологда (8172)26-41-59
Воронеж (473)204-51-73
Екатеринбург (343)384-55-89
Иваново (4932)77-34-06
Ижевск (3412)26-03-58
Казань (843)206-01-48

Калининград (4012)72-03-81
Калуга (4842)92-23-67
Кемерово (3842)65-04-62
Киров (8332)68-02-04
Краснодар (861)203-40-90
Красноярск (391)204-63-61
Курск (4712)77-13-04
Липецк (4742)52-20-81
Магнитогорск (3519)55-03-13
Москва (495)268-04-70
Мурманск (8152)59-64-93
Набережные Челны (8552)20-53-41

Нижний Новгород (831)429-08-12
Новокузнецк (3843)20-46-81
Новосибирск (383)227-86-73
Орел (4862)44-53-42
Оренбург (3532)37-68-04
Пенза (8412)22-31-16
Пермь (342)205-81-47
Ростов-на-Дону (863)308-18-15
Рязань (4912)46-61-64
Самара (846)206-03-16
Санкт-Петербург (812)309-46-40
Саратов (845)249-38-78

Смоленск (4812)29-41-54
Сочи (862)225-72-31
Ставрополь (8652)20-65-13
Тверь (4822)63-31-35
Томск (3822)98-41-53
Тула (4872)74-02-29
Тюмень (3452)66-21-18
Ульяновск (8422)24-23-59
Уфа (347)229-48-12
Челябинск (351)202-03-61
Череповец (8202)49-02-64
Ярославль (4852)69-52-93

Force

- » Peak: 156 - 780 N
- » Continuous: 42 - 102 N

Maximum Velocity

- » Up to 8.5 m/s

Feedback

- » Built-in position sensor
- » 1V pk-pk sin/cos
- » 12 micron repeatability
- » Optionally with high resolution encoder

Range of motion

- » Strokes up to 1151 mm

Dimensions

- » W x H: 110 x 164 mm
- » Rod diameters: 25 mm

Applications

- » Packaging
- » Material Handling
- » Automated Assembly
- » Bio-medical

The OEM advantage

- » Easy integration
- » Flexible position control
- » High speed and acceleration
- » Clean, quiet operation
- » Low maintenance

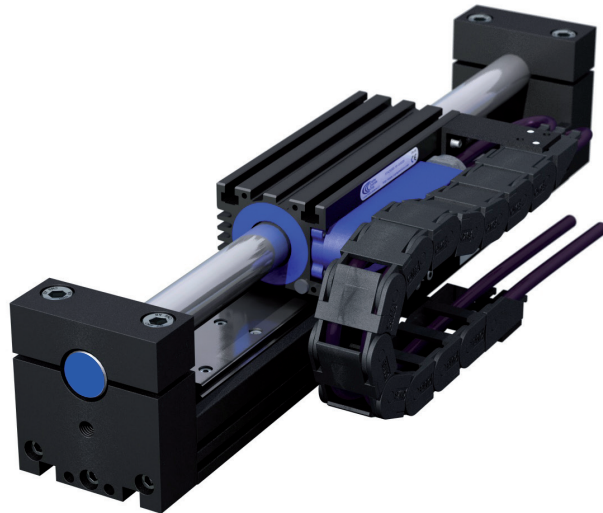

The ServoTube Module with fully integrated bearing rail and position encoder offers unprecedented value in high performance applications. The ServoTube Module is a cost effective alternative to ballscrew and belt drive systems where high speed and flexibility are required.

Four models deliver a continuous force of 42~102 N (9~23lb) with peak forces of up to 780 N (175lb). Standard stroke lengths of 14~1151 mm are available.

The patented magnetic design of ServoTube generates 12 micron (0.47 mil) repeatability and 350 micron (14 mil) absolute accuracy, from a non-contact, integral position sensor. The standard ServoTube position encoder output is an industry standard 1V pk-pk sin/cos signal. For applications requiring higher levels of accuracy, the ServoTube Module is available with a fully integrated optical position encoder giving a resolution of 1 micron.

The non-contact nature of the direct linear drive results in life expectancy far above that for typical belt drive and ballscrew systems, with the added advantage of no deterioration in accuracy or repeatability over the entire life of the product.

The ServoTube Module is an ideal OEM solution for easy integration into pick-and-place gantry and general purpose material handling machines. The load is mounted directly to the forcer giving a very stable base. Servotube Modules can be easily integrated with each other or with other ServoTube products to create multi axis systems with minimal design effort.

The ServoTube has superior thermal efficiency, radiating heat uniformly. High duty cycles are possible without the need for forced-air or water cooling.

ELECTRICAL SPECIFICATIONS

FORCER TYPE	2504		2506		2508		2510		units
	S ⁽¹⁾	P ⁽¹⁾	S ⁽¹⁾	P ⁽¹⁾	S ⁽¹⁾	P ⁽¹⁾	S ⁽¹⁾	P ⁽¹⁾	
Peak force @ 25°C ambient for 1 sec	312	156	468	234	624	312	780	390	N
Peak current @ 25°C ambient for 1 sec	20								Apk
With 25 x 25 x2.5cm heatsink plate									
Continuous stall force @ 25°C ambient ⁽²⁾	51.2		69.5		86.4		102.4		N
Continuous stall current @ 25°C ambient	2.31	4.62	2.10	4.20	1.96	3.92	1.86	3.72	Arms
	3.27	6.54	2.97	5.94	2.77	5.54	2.62	5.24	Apk
Without heatsink plate									
Continuous stall force @ 25°C ambient ⁽²⁾	42.5		59.5		75.1		90.0		N
Continuous stall current @ 25°C ambient	1.92	3.84	1.80	3.60	1.70	3.40	1.63	3.26	Arms
	2.72	5.44	2.54	5.08	2.41	4.82	2.31	4.62	Apk
Force constant (sine commutation)	22.1	11.0	33.1	16.5	44.1	22.0	55.2	27.6	N/Arms
	15.6	7.8	23.4	11.7	31.2	15.6	39.0	19.5	N/Apk
Back EMF constant (phase to phase)	18.0	9.0	27.0	13.5	36.0	18.0	45.0	22.5	Vpk/m/s
Fundamental forcer constant	6.47		7.92		9.13		10.24		N/√W
Eddy current loss	9.51		12.55		15.58		18.61		N/m/s
Resistance @ 25°C (phase to phase)	6.02	1.50	9.02	2.25	12.03	3.01	15.04	3.76	Ohm
Resistance @ 100°C (phase to phase)	7.75	1.94	11.63	2.91	15.51	3.88	19.39	4.85	Ohm
Inductance @ 1kHz (phase to phase)	3.90	0.97	5.85	1.46	7.80	1.95	9.75	2.44	mH
Electrical time constant	0.65								ms
Maximum working voltage	380								V d.c.
Pole pitch (one electrical cycle)	51.2								mm
Peak acceleration ⁽³⁾	222	111	222	111	235	117	255	127	m/s ²
Maximum speed ⁽⁴⁾	8.5	7.3	6.4	7.1	5.3	7.3	4.5	6.7	m/s

Notes: -

⁽¹⁾ S=series forcer phases, P=parallel forcer phases

⁽²⁾ Reduce continuous stall force to 89% at 40°C ambient

⁽³⁾ Based on a moving forcer with no payload

⁽⁴⁾ Based on a moving forcer with triangular move over maximum stroke and no payload

THERMAL SPECIFICATIONS

FORCER TYPE	2504	2506	2508	2510	units
Maximum phase temperature	100				°C
Thermal resistance $R_{th, phase-housing}$	0.41	0.27	0.20	0.16	°C/Watt
With 25 x 25 x2.5cm heatsink plate					
Power dissipation @ 25°C ambient	62.3	77.0	89.2	100.2	Watt
Thermal resistance $R_{th, housing-ambient}$	0.79	0.69	0.64	0.59	°C/Watt
Without heatsink plate					
Power dissipation @ 25°C ambient	43.1	56.4	67.6	77.3	Watt
Thermal resistance $R_{th, housing-ambient}$	1.33	1.06	0.91	0.81	°C/Watt
Thermal time constant	1188	1276	1377	1486	s

MECHANICAL SPECIFICATIONS

FORCER TYPE	2504	2506	2508	2510	units
Maximum stroke	1151	1100	1049	998	mm
Moving mass	1.40	2.10	2.65	3.05	kg
Maximum normal force, $F_n^{(1)(3)}$	1.05	2.11			kN
Maximum side force, $F_s^{(1)}$					
Maximum roll moment, $M_r^{(1)}$	17.8	35.6			Nm
Maximum pitch moment, $M_p^{(1)}$	6.4	112	158	212	Nm
Maximum yaw moment, $M_y^{(1)}$					
Maximum normal force, $F_n^{(2)(3)}$	0.49	0.98			kN
Maximum side force, $F_s^{(2)}$					
Maximum roll moment, $M_r^{(2)}$	8.2	16.4			Nm
Maximum pitch moment, $M_p^{(2)}$	2.9	52	73	98	Nm
Maximum yaw moment, $M_y^{(2)}$					
Constrained vertical straightness (flatness)	60				µm/m
Constrained horizontal straightness	80				µm/m
Unconstrained vertical straightness (flatness)	100				µm/m
Unconstrained horizontal straightness	80				µm/m

Notes: -

(1) For a bearing life expectancy of 10000 km with no other forces or moments

(2) For a bearing life expectancy of 100000 km with no other forces or moments

(3) Load in kg = force/9.81

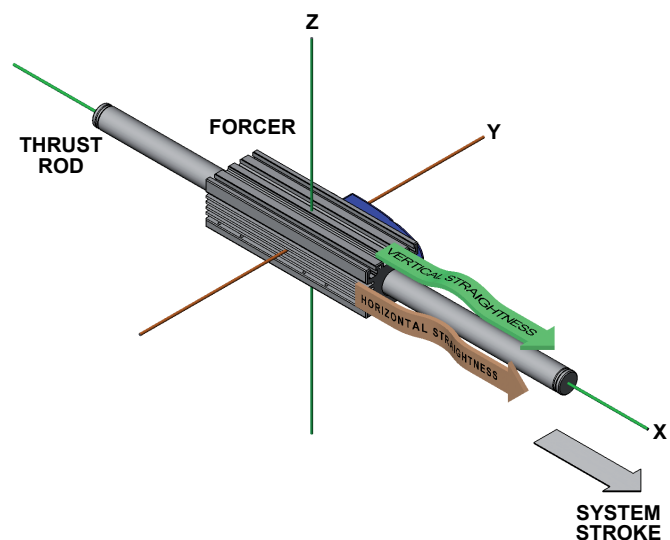
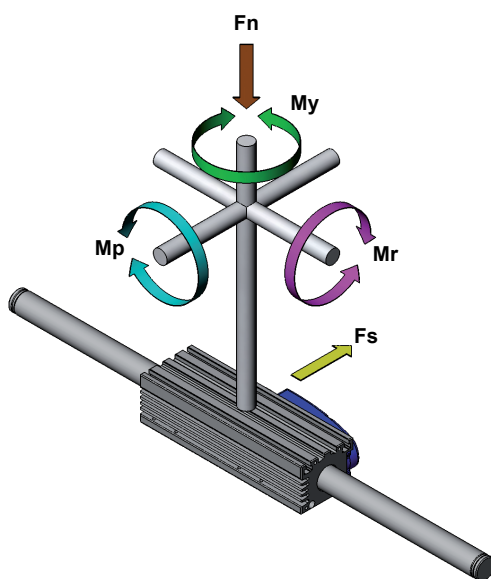

OUTLINE DRAWINGS

SM25

FORCER	FORCER LENGTH (mm)	WITH BUFFERS (mm)
2504	160	164
2506	211	215
2508	262	266
2510	313	317

CABLES:

1. Ø7.6 POWER CABLE
2. Ø5.8 SENSOR CABLE
3. Ø4.5 ENCODER CABLE (OPTIONAL)

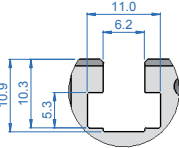
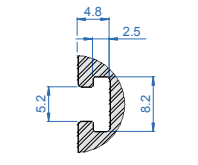
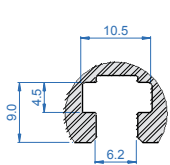
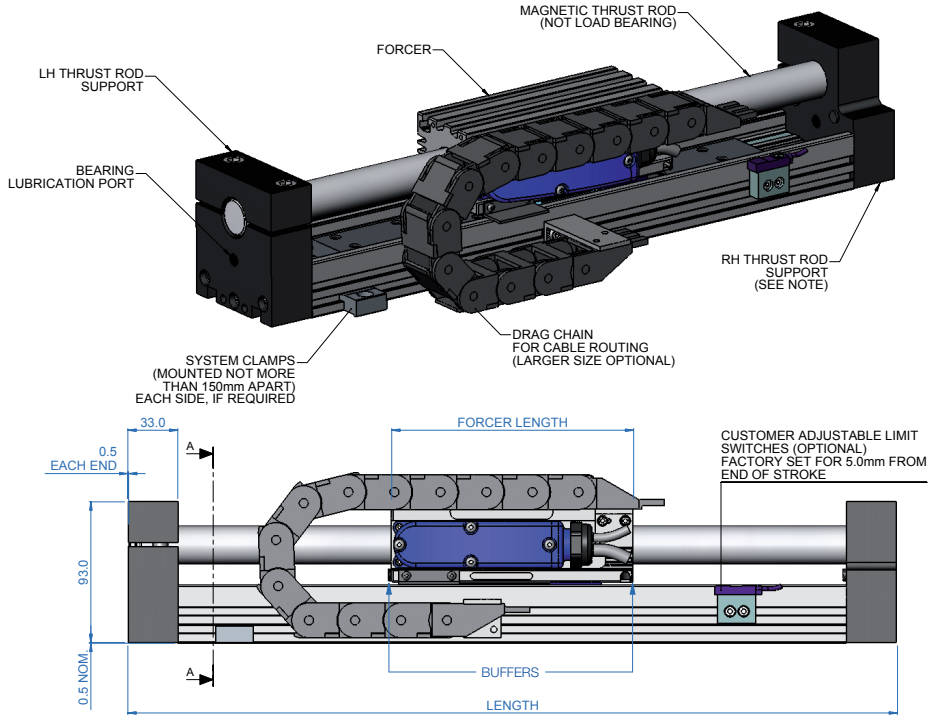
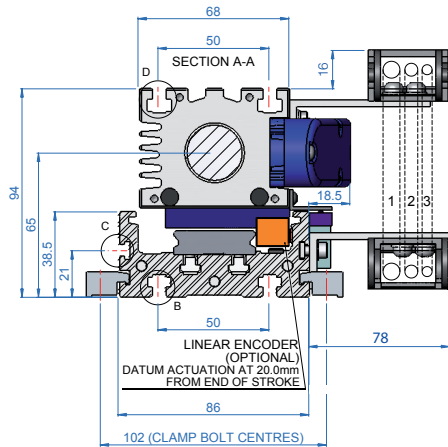

NOTE:
RH THRUST ROD SUPPORT SHOWN IS FOR 2504 MODULES ONLY. FOR ALL OTHER SIZES THIS SUPPORT WILL BE AS LH THRUST ROD SUPPORT.

Length	Stroke			
	2504	2506	2508	2510
253	23	-	-	-
278	48	-	-	-
304	74	23	-	-
330	100	49	-	-
355	125	74	23	-
381	151	100	49	-
406	176	125	74	23
432	202	151	100	49
458	228	177	126	75
483	253	202	151	100
509	279	228	177	126
535	305	254	203	152
560	330	279	228	177
586	356	305	254	203
612	382	331	280	229
637	407	356	305	254
663	433	382	331	280

Length	Stroke			
	2504	2506	2508	2510
689	459	408	357	306
714	484	433	382	331
740	510	459	408	357
766	536	485	434	383
791	561	510	459	408
817	587	536	485	434
868	638	587	536	485
919	689	638	587	536
971	741	690	639	588
1022	792	741	690	639
1073	843	792	741	690
1125	895	844	793	742
1176	946	895	844	793
1227	997	946	895	844
1279	1049	998	947	896
1330	1100	1049	998	947
1381	1151	1100	1049	998

Approximate module mass (kg)			
2504	2506	2508	2510
$(0.0108 \times L) + 3.35$	$(0.0108 \times L) + 3.04$	$(0.0108 \times L) + 3.58$	$(0.0108 \times L) + 3.96$
where L = Length in mm			

SB25 (on request)

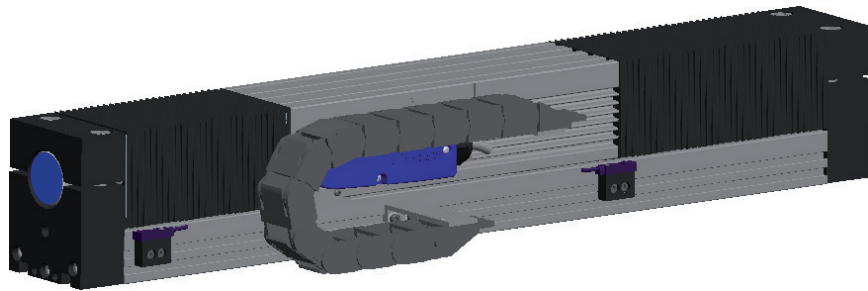

12

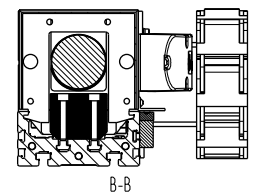
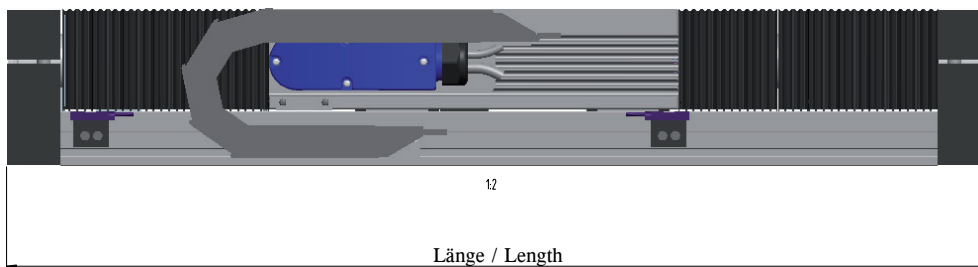

Length	Stroke			
	2504	2506	2508	2510
253	-	-	-	-
278	-	-	-	-
304	14	-	-	-
330	40	-	-	-
355	65	14	-	-
381	91	40	-	-
406	114	65	14	-
432	134	91	40	-
458	148	115	66	15
483	165	134	91	40
509	183	148	115	66
535	197	166	135	91
560	214	183	148	115
586	230	197	166	135
612	248	215	184	149
637	265	230	197	166
663	297	248	215	184

Length	Stroke			
	2504	2506	2508	2510
689	297	266	231	198
714	312	279	248	215
740	330	297	266	231
766	348	313	280	249
791	361	330	297	266
817	379	348	313	280
868	412	379	348	313
919	443	412	379	348
971	481	444	413	380
1022	512	481	444	413
1073	543	512	481	444
1125	577	544	513	478
1176	608	577	544	513
1227	643	608	577	544
1279	677	644	609	578
1330	708	677	644	609
1381	741	708	677	644

Approximate module mass (kg)			
2504	2506	2508	2510
$(0.00885 \times L)+2.49$	$(0.00885 \times L)+2.94$	$(0.00885 \times L)+3.49$	$(0.00885 \times L)+3.85$
where L = Length in mm			

FEEDBACK

The ServoTube Module is available with three feedback options with option S supplied as standard.

Option S feedback outputs analogue, differential sine and cosine signals for providing position feedback. Shown below are the relationships between forcer phase back EMF and position sensor outputs for one direction of motion (as shown by arrows). It should be noted that +SIN or -SIN is always in phase with forcer phase U. For the motion shown, -SIN is in phase with forcer phase U. For motion in the opposing direction +SIN is in phase with forcer phase U.

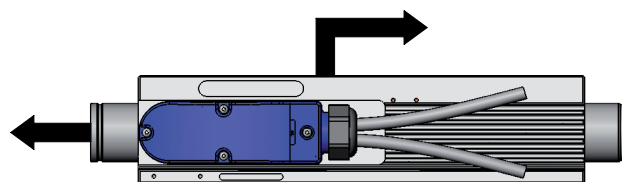
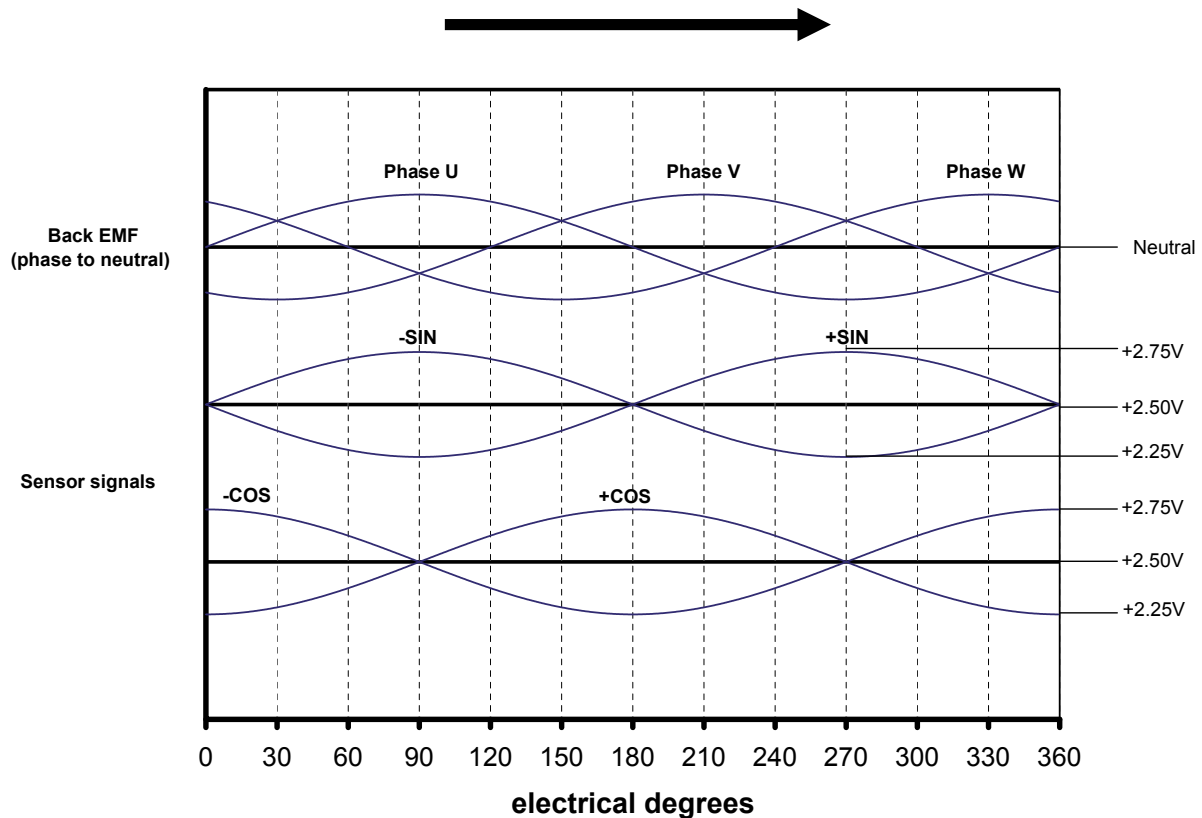

OPTION S SPECIFICATION	Sx25	units
Output signal period	51.2	mm
Signal amplitude (between +/- signals)	1	V _{pk-pk}
Output current	± 10	mA
Supply voltage	5 ± 0.25	V _{d.c.}
Supply current (output current=0)	15 ± 5	mA
Resolution ⁽¹⁾	12	µm
Position repeatability ⁽²⁾	± 12	µm
Absolute accuracy ⁽³⁾	± 350	µm

Notes: -

⁽¹⁾ Dependent on amplifier (indication with 12 bit resolution)

⁽²⁾ Dependent on amplifier. Under constant operating conditions. Self-heating of the forcer will cause expansion in the thrust rod during the initial warm up period. In high duty applications (corresponding to an internal forcer temperature of 80°C) a 1 metre thrust rod will expand typically by 250 µm.

⁽³⁾ Maximum error over 1 metre under constant operating conditions.

If improved positional accuracy is required, then in addition to option S, one external encoder option is available.

Option C uses the Renishaw RGH24X optical encoder. This option provides two channels, A and B, in phase quadrature (90° phase separated). A reference channel, Z, is also available that produces a single output at a position set by a reference mark.

SPECIFICATION	OPTION C	units
Signal output	EIA RS422A	-
Supply voltage	5 ± 0.25	Vd.c.
Supply current (output current=0)	120	mA
Supply current (outputs terminated with 120R)	195	mA
Resolution	1	µm
Position repeatability ⁽¹⁾	± 1	µm
Absolute accuracy ⁽²⁾	± 10	µm

Notes: -

⁽¹⁾ Dependent on amplifier. Under constant operating conditions.

⁽²⁾ Typical maximum error over 1 metre under constant operating conditions.

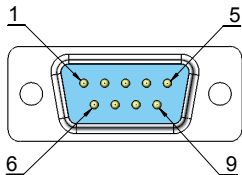

Connections are available via a 9-way D-sub male connector.

FUNCTION	+5Vd.c.	0V	A+	A-	B+	B-	Z+	Z-	Screen
PIN NUMBER	5	1	2	6	4	8	3	7	CASE

FORCER OVER-TEMPERATURE SENSOR



It is strongly recommended that the forcer over-temperature sensor is connected to the drive amplifier or servo controller **at all times** in order to reduce the risk of damage to the forcer due to excessive temperatures.

Protection is provided by three positive temperature coefficient (PTC) thermistors embedded in the forcer phases. As the forcer phase temperature approaches 100°C, the PTC thermistors exhibits a sharp increase in electrical resistance. This change in resistance can be detected by circuitry within the drive amplifier or servo controller and used to reduce or disable the output of the drive amplifier in order to protect the forcer.

SPECIFICATION	VALUE	units
Resistance in the temperature range -20°C to + 70°C	60 to 750	Ohms
Resistance at 85°C	≤1650	Ohms
Resistance at 95°C	≥3990	Ohms
Resistance at 105°C	≥12000	Ohms
Maximum continuous voltage	30	Vd.c.

FORCER ELECTRICAL CONNECTIONS

Connections are made within the termination box.

PIN NUMBER	FUNCTION
1	Phase U
2	Phase V
3	Phase W
Chassis	Earth/Screen

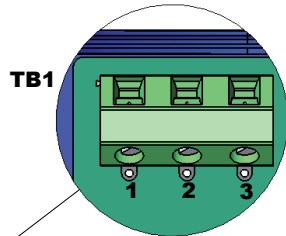

PIN NUMBER	FUNCTION
1	+SIN
2	-SIN
3	+COS
4	-COS
5	+5Vd.c.
6	0V
7	+TH (Thermistor)
8	-TH (Thermistor)

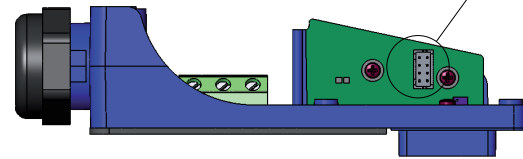
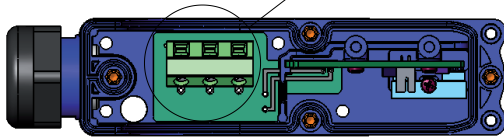
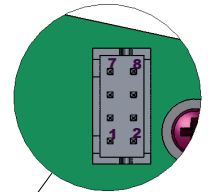

CABLE

The ServoTube Module has two separate cables providing connections for forcer power and position sensor. The cables are available in 3 metre, 5 metre and 10 metre lengths.

SPECIFICATION	POWER	SENSOR
Overall diameter (nominal)	8.0mm	5.8mm
Outer jacket material	PUR	PUR
Number of conductors	4	4 x twisted pair
Size of conductors	1.5mm ² (16 AWG)	0.14mm ² (26 AWG)
Screened / Unscreened	Screened	Screened
Minimum bending radius - flexible routing	42mm	42mm
Operating temperature - flexible routing	-15°C to +80°C	-15°C to +80°C
Operating temperature - fixed routing	-30°C to +80°C	-30°C to +80°C

CABLE TERMINATION

The ServoTube Module cable is available with three termination options. **Option F** has the wire ends stripped and solder tinned ready for termination. All other options are terminated with connectors that plug directly into the desired amplifier. The connections for all options are shown below: -

SENSOR FUNCTION	D - (XTL-S)	N - (ESR-Pollmeier)	F - (Flying leads)
+SIN	14	6	Blue
-SIN	13	7	Red
+COS	12	11	White
-COS	11	12	Brown
+5Vd.c.	4	10	Yellow
0V	5	15	Green
+TH (Thermistor)	10	5	Pink
-TH (Thermistor)	15	15	Grey
SCREEN	1+ shell	Shell	SCREEN
Connector type	15-way high density D	15-way high density D	-
Amplifier connection	J8	X6.2	-
POWER FUNCTION			
Forcer phase U	4	U	Black <u>1</u>
Forcer phase V	3	V	Black <u>2</u>
Forcer phase W	2	W	Black <u>3</u>
Earth (forcer body)	1	PE	Green/Yellow
SCREEN	1	Shell	SCREEN
Connector type	4-way 5mm pluggable terminal	4-way pluggable terminal	-
Amplifier connection	J2	X3	-

LIMITS



These limit switches are not intended as safety devices or as part of a system intended to ensure personal safety. When two switches are mounted in close proximity (as in the case of a left and right limit switch), a minimum of 30mm spacing between sense areas must be maintained.

If required, the ServoTube Module can be supplied with limit switches. There are two types available, NPN output and PNP output. Each output type is available with 2 metres of robotics cable. Each limit switch position is adjustable and switching is achieved by an actuator vane mounted on the forcer. Electrical connections are made via wire ends stripped and solder tinned ready for termination.

SPECIFICATION	VALUE			
	minimum	typical	maximum	units
Supply voltage	10	24	30	Vd.c.
Supply current	-	15	-	mA
Sink current	-	-	100	mA
"Closed" voltage	-	-	1	Vd.c.
Frequency response	-	-	600	Hz

The output for all types can be either a normally closed (NC, opener) or normally open (NO, closer) open collector transistor. A red indicator shows the output status.

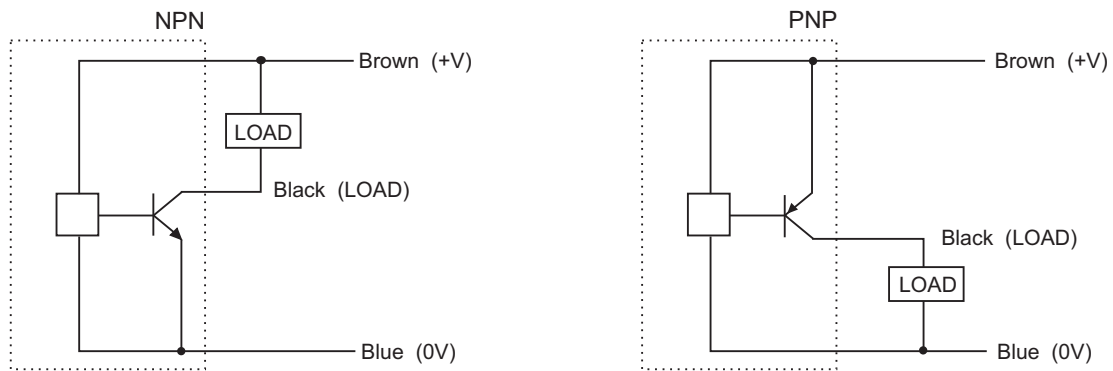

DRAG CHAIN

Size 15.3 is standard. Smaller drag chains on request.

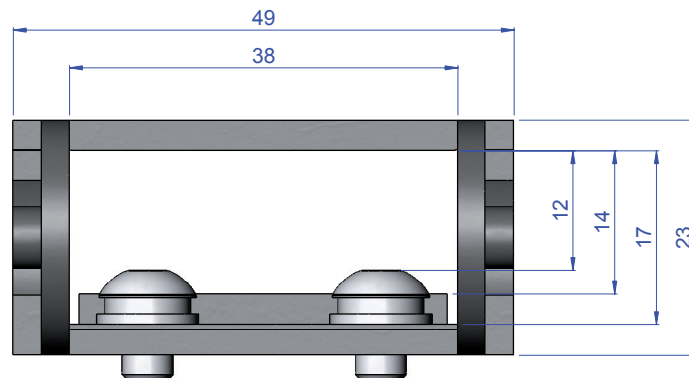

ENVIRONMENT

The ServoTube Module is intended for use in an environment within the following conditions: -

SPECIFICATION	VALUE
Operating temperature	0°C to +40°C
Storage temperature	-20°C to +70°C
Altitude (above mean sea level)	1000m
Overvoltage category	II
Pollution degree	2
EMC	light industrial

ORDER CODES

Module

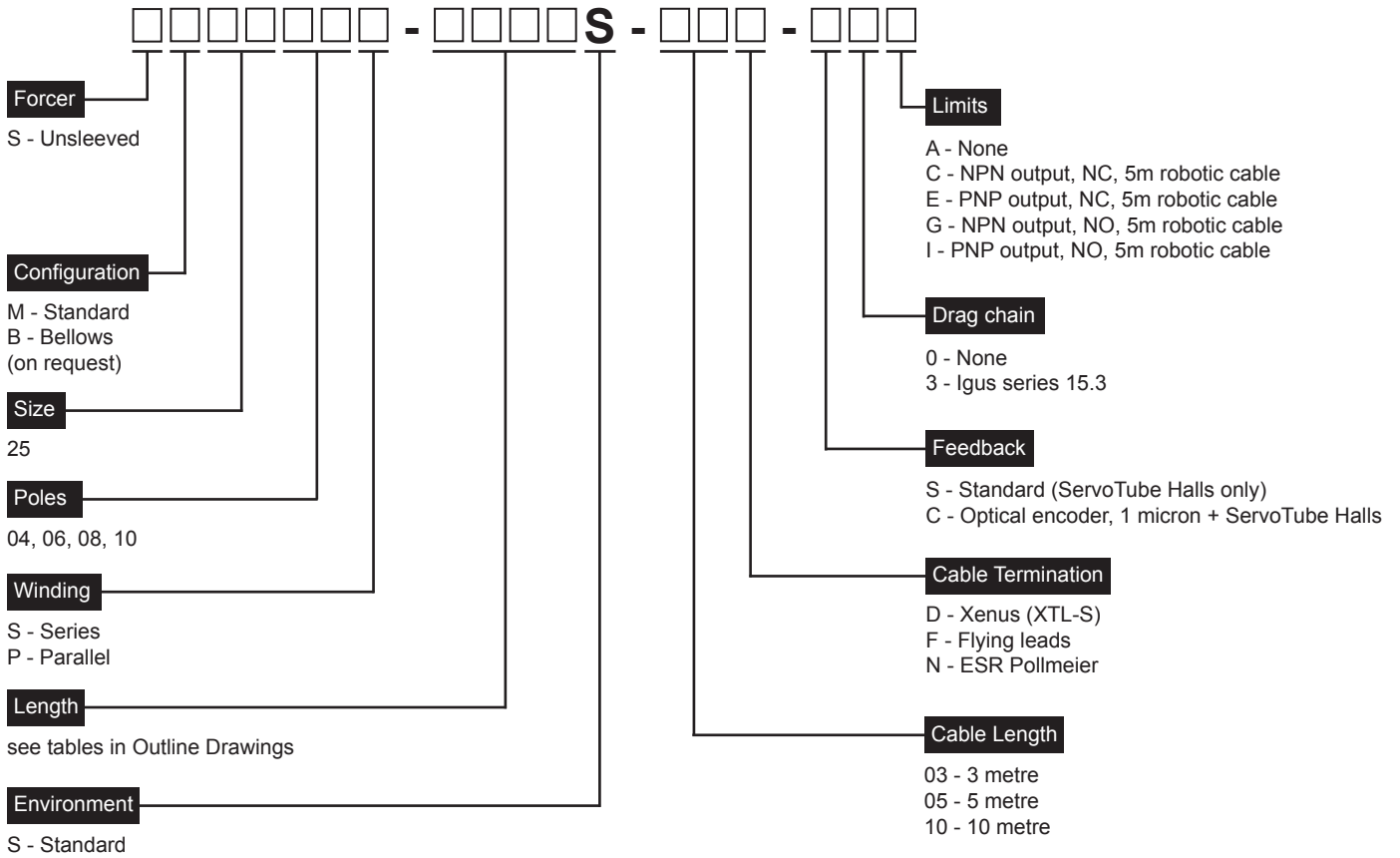

По вопросам продажи и поддержки обращайтесь:

Архангельск (8182)63-90-72
Астана +7(7172)727-132
Белгород (4722)40-23-64
Брянск (4832)59-03-52
Владивосток (423)249-28-31
Волгоград (844)278-03-48
Вологда (8172)26-41-59
Воронеж (473)204-51-73
Екатеринбург (343)384-55-89
Иваново (4932)77-34-06
Ижевск (3412)26-03-58
Казань (843)206-01-48

Калининград (4012)72-03-81
Калуга (4842)92-23-67
Кемерово (3842)65-04-62
Киров (8332)68-02-04
Краснодар (861)203-40-90
Красноярск (391)204-63-61
Курск (4712)77-13-04
Липецк (4742)52-20-81
Магнитогорск (3519)55-03-13
Москва (495)268-04-70
Мурманск (8152)59-64-93
Набережные Челны (8552)20-53-41

Нижний Новгород (831)429-08-12
Новокузнецк (3843)20-46-81
Новосибирск (383)227-86-73
Орел (4862)44-53-42
Оренбург (3532)37-68-04
Пенза (8412)22-31-16
Пермь (342)205-81-47
Ростов-на-Дону (863)308-18-15
Рязань (4912)46-61-64
Самара (846)206-03-16
Санкт-Петербург (812)309-46-40
Саратов (845)249-38-78

Смоленск (4812)29-41-54
Сочи (862)225-72-31
Ставрополь (8652)20-65-13
Тверь (4822)63-31-35
Томск (3822)98-41-53
Тула (4872)74-02-29
Тюмень (3452)66-21-18
Ульяновск (8422)24-23-59
Уфа (347)229-48-12
Челябинск (351)202-03-61
Череповец (8202)49-02-64
Ярославль (4852)69-52-93

Единый адрес для всех регионов: dre@nt-rt.ru || www.dunker.nt-rt.ru