



ЛИНЕЙНЫЕ ДВИГАТЕЛИ XM 38

Архангельск (8182)63-90-72
Астана +7(7172)727-132
Белгород (4722)40-23-64
Брянск (4832)59-03-52
Владивосток (423)249-28-31
Волгоград (844)278-03-48
Вологда (8172)26-41-59
Воронеж (473)204-51-73
Екатеринбург (343)384-55-89
Иваново (4932)77-34-06
Ижевск (3412)26-03-58
Казань (843)206-01-48

Калининград (4012)72-03-81
Калуга (4842)92-23-67
Кемерово (3842)65-04-62
Киров (8332)68-02-04
Краснодар (861)203-40-90
Красноярск (391)204-63-61
Курск (4712)77-13-04
Липецк (4742)52-20-81
Магнитогорск (3519)55-03-13
Москва (495)268-04-70
Мурманск (8152)59-64-93
Набережные Челны (8552)20-53-41

Нижний Новгород (831)429-08-12
Новокузнецк (3843)20-46-81
Новосибирск (383)227-86-73
Орел (4862)44-53-42
Оренбург (3532)37-68-04
Пенза (8412)22-31-16
Пермь (342)205-81-47
Ростов-на-Дону (863)308-18-15
Рязань (4912)46-61-64
Самара (846)206-03-16
Санкт-Петербург (812)309-46-40
Саратов (845)249-38-78

Смоленск (4812)29-41-54
Сочи (862)225-72-31
Ставрополь (8652)20-65-13
Тверь (4822)63-31-35
Томск (3822)98-41-53
Тула (4872)74-02-29
Тюмень (3452)66-21-18
Ульяновск (8422)24-23-59
Уфа (347)229-48-12
Челябинск (351)202-03-61
Череповец (8202)49-02-64
Ярославль (4852)69-52-93

Force

- » Peak: 312 - 1860 N
- » Continuous: 120 - 276N

Maximum Velocity

- » Up to 8.7 m/s

Feedback

- » Built-in position sensor
- » 1V pk-pk sin/cos
- » 20 micron repeatability
- » Optionally with high resolution encoder

Range of motion

- » Strokes up to 1323 mm

Dimensions

- » W x H: 110 x 176 mm
- » Rod diameters: 38mm

Applications

- » Packaging
- » Material Handling
- » Automated Assembly
- » Bio-medical

The OEM advantage

- » Easy integration
- » Flexible position control
- » High speed and acceleration
- » Clean, quiet operation
- » Low maintenance

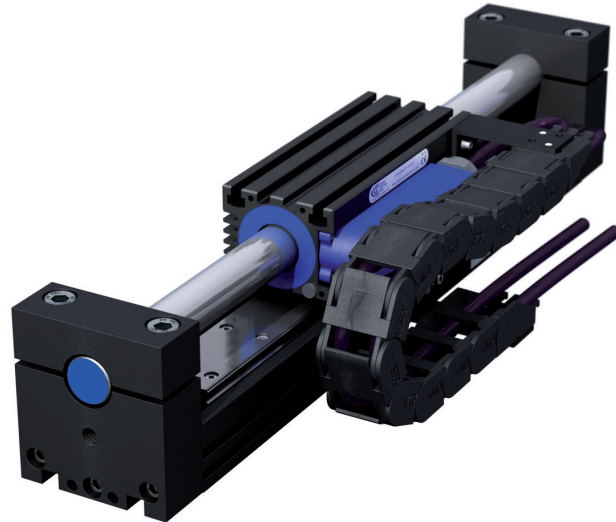

The ServoTube Module with fully integrated bearing rail and position encoder offers unprecedented value in high performance applications. The ServoTube Module is a cost effective alternative to ballscrew and belt drive systems where high speed and flexibility are required.

Four models deliver a continuous force of 120~276N (27~62lb) with peak forces of up to 1860N (418lb). Standard stroke lengths of 15~1323 mm are available.

The patented magnetic design of ServoTube generates 20 micron (0.79 mil) repeatability and 400 micron (15,75 mil) absolute accuracy, from a non-contact, integral position sensor. The standard ServoTube position encoder output is an industry standard 1V pk-pk sin/cos signal. For applications requiring higher levels of accuracy, the ServoTube Module is available with a fully integrated optical position encoder giving a resolution of 1 micron.

The non-contact nature of the direct linear drive results in life expectancy far above that for typical belt drive and ballscrew systems, with the added advantage of no deterioration in accuracy or repeatability over the entire life of the product.

The ServoTube Module is an ideal OEM solution for easy integration into pick-and-place gantry and general purpose material handling machines. The load is mounted directly to the forcer giving a very stable base. Servotube Modules can be easily integrated with each other or with other ServoTube products to create multi axis systems with minimal design effort.

The ServoTube has superior thermal efficiency, radiating heat uniformly. High duty cycles are possible without the need for forced-air or water cooling.

ELECTRICAL SPECIFICATIONS

FORCER TYPE	3804		3806		3808		3810		units
	S ⁽¹⁾	P ⁽¹⁾	S ⁽¹⁾	P ⁽¹⁾	S ⁽¹⁾	P ⁽¹⁾	S ⁽¹⁾	P ⁽¹⁾	
Peak force @ 25°C ambient for 1 sec	744	372	1116	558	1488	744	1860	930	N
Peak current @ 25°C ambient for 1 sec	20								Apk
With 25 x 25 x2.5cm heatsink plate									
Continuous stall force @ 25°C ambient ⁽²⁾	137.3		186.9		232.1		276.2		N
Continuous stall current @ 25°C ambient	2.61	5.23	2.37	4.74	2.20	4.41	2.10	4.20	Arms
	3.69	7.39	3.35	6.71	3.12	6.23	2.97	5.94	Apk
Without heatsink plate									
Continuous stall force @ 25°C ambient ⁽²⁾	120.1		168.2		212.7		255.0		N
Continuous stall current @ 25°C ambient	2.28	4.57	2.13	4.27	2.02	4.04	1.94	3.88	Arms
	3.23	6.46	3.01	6.03	2.86	5.72	2.74	5.49	Apk
Force constant (sine commutation)	52.6	26.3	78.9	39.4	105.2	52.6	131.5	65.7	N/Arms
	37.2	18.6	55.8	27.9	74.4	37.2	93.0	46.5	N/Apk
Back EMF constant (phase to phase)	43.0	21.5	64.4	32.2	85.9	42.9	107.4	53.7	Vpk/m/s
Fundamental forcer constant	14.54		17.80		20.56		22.99		N/√W
Eddy current loss	3.7		3.7		3.7		3.7		N/m/s
Sleeve cogging force	7.3		4.2		8.3		5.6		+/-N
Resistance @ 25°C (phase to phase)	6.77	1.69	10.16	2.54	13.54	3.38	16.93	4.23	Ohm
Resistance @ 100°C (phase to phase)	8.73	2.18	13.10	3.27	17.45	4.36	21.82	5.45	Ohm
Inductance @ 1kHz (phase to phase)	8.52	2.13	12.78	3.19	17.04	4.26	21.30	5.32	mH
Electrical time constant	1.26								ms
Maximum working voltage	380								V d.c.
Pole pitch (one electrical cycle)	71.2								mm
Peak acceleration ⁽³⁾	243	121	275	137	294	147	307	153	m/s ²
Maximum speed ⁽⁴⁾	5.9	8.7	4.2	7.1	3.3	5.8	2.6	4.9	m/s

Notes: -

⁽¹⁾ S=series forcer phases, P=parallel forcer phases

⁽²⁾ Reduce continuous stall force to 89% at 40°C ambient

⁽³⁾ Based on a moving forcer with no payload

⁽⁴⁾ Based on a moving forcer with triangular move over maximum stroke and no payload

THERMAL SPECIFICATIONS

FORCER TYPE	3804	3806	3808	3810	units
Maximum phase temperature	100				°C
Thermal resistance $R_{th, \text{phase-housing}}$	0.23	0.16	0.13	0.11	°C/Watt
With 25 x 25 x 2.5cm heatsink plate					
Power dissipation @ 25°C ambient	89.3	110.3	127.1	144.2	Watt
Thermal resistance $R_{th, \text{housing-ambient}}$	0.61	0.52	0.46	0.41	°C/Watt
Without heatsink plate					
Power dissipation @ 25°C ambient	68.2	89.3	107.0	123.0	Watt
Thermal resistance $R_{th, \text{housing-ambient}}$	0.87	0.68	0.57	0.50	°C/Watt
Thermal time constant	1677	1798	1924	2056	s

MECHANICAL SPECIFICATIONS

FORCER TYPE	3804	3806	3808	3810	units
Maximum stroke	1323	1252	1181	1110	mm
Moving mass	3.05	4.05	5.05	6.05	kg
Maximum normal force, $F_n^{(1)(3)}$	2.11				kN
Maximum side force, $F_s^{(1)}$	35.6				Nm
Maximum roll moment, $M_r^{(1)}$	35.6				Nm
Maximum pitch moment, $M_p^{(1)}$	103	172	238	313	Nm
Maximum yaw moment, $M_y^{(1)}$	0.98				kN
Maximum normal force, $F_n^{(2)(3)}$	0.98				kN
Maximum side force, $F_s^{(2)}$	16.4				Nm
Maximum roll moment, $M_r^{(2)}$	16.4				Nm
Maximum pitch moment, $M_p^{(2)}$	48	79	110	145	Nm
Maximum yaw moment, $M_y^{(2)}$	80				µm/m
Constrained vertical straightness (flatness)	80				µm/m
Constrained horizontal straightness	100				µm/m
Unconstrained vertical straightness (flatness)	80				µm/m
Unconstrained horizontal straightness	80				µm/m

Notes: -

(1) For a bearing life expectancy of 10000 km with no other forces or moments

(2) For a bearing life expectancy of 100000 km with no other forces or moments

(3) Load in kg = force/9.81

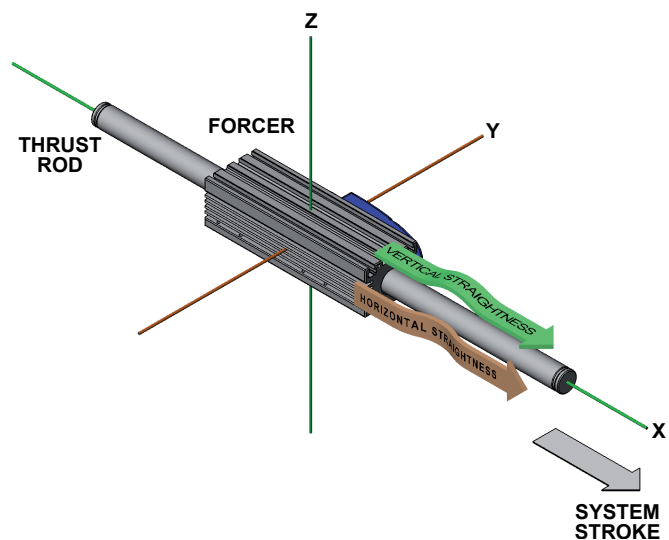
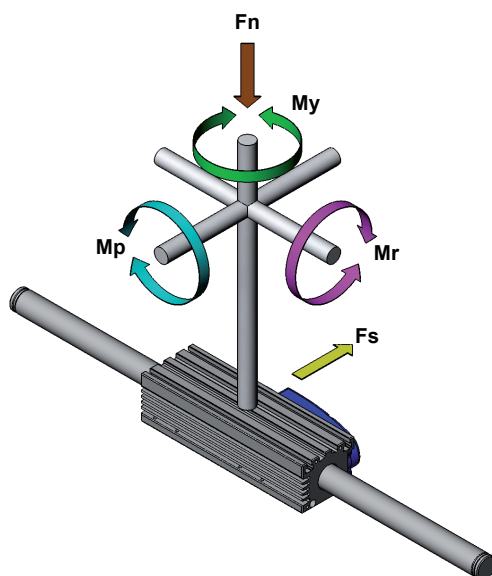

OUTLINE DRAWINGS

XM38

FORCER	FORCER LENGTH (mm)	WITH BUFFERS (mm)
3804	218	222
3806	289	293
3808	360	364
3810	431	435

CABLES:

1. Ø7.6 POWER CABLE
2. Ø5.8 SENSOR CABLE
3. Ø4.5 ENCODER CABLE (OPTIONAL)

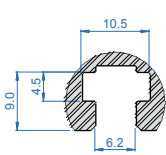
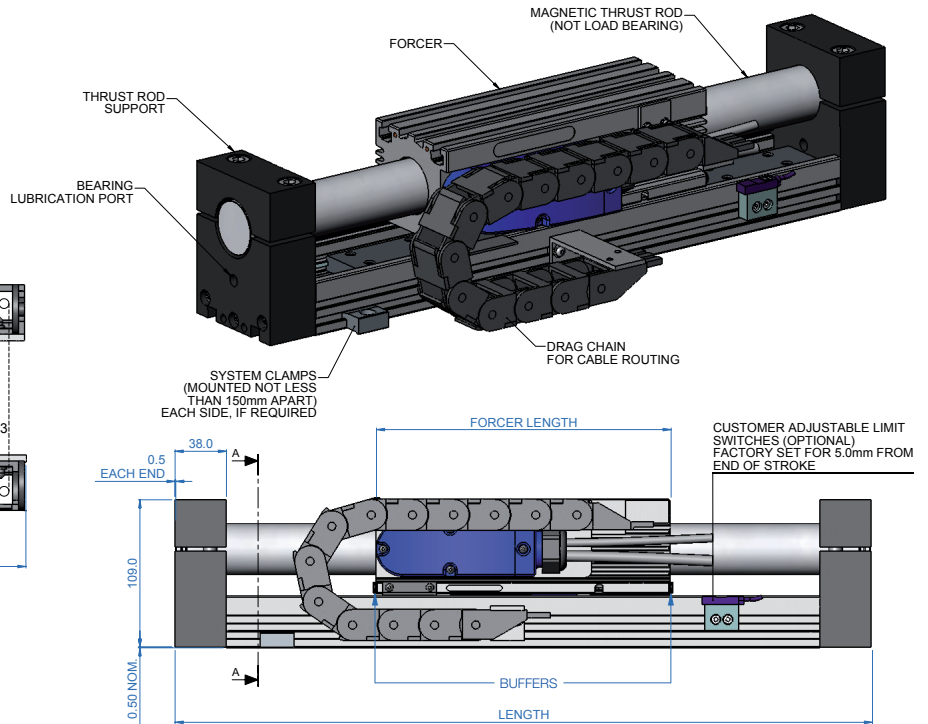
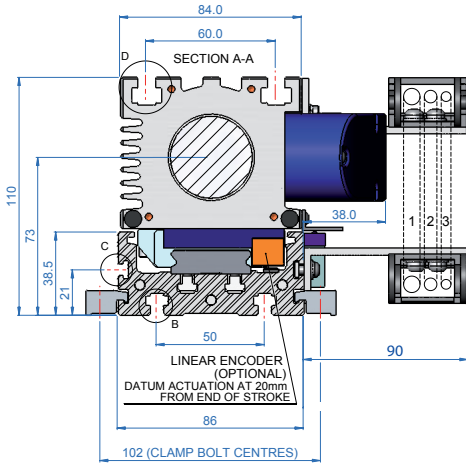

DETAIL B
SLOTS FOR M5 T-NUTS & M6 SQUARE / HEX. NUTS

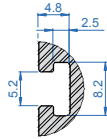

DETAIL C
SLOTS FOR M4 SQUARE NUTS

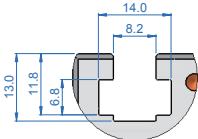

DETAIL D
SLOTS FOR M6 T-NUTS & M8 SQUARE / HEX. NUTS

Length	Stroke			
	3804	3806	3808	3810
338	40	-	-	-
373	75	-	-	-
409	111	40	-	-
445	147	76	-	-
480	182	111	40	-
516	218	147	76	-
551	253	182	111	40
587	289	218	147	76
623	325	254	183	112
658	360	289	218	147
694	396	325	254	183
730	432	361	290	219
765	467	396	325	254
801	503	432	361	290
837	539	468	397	326
872	574	503	432	361
908	610	539	468	397
944	646	575	504	433
979	681	610	539	468

Length	Stroke			
	3804	3806	3808	3810
1015	717	646	575	504
1051	753	682	611	540
1086	788	717	646	575
1122	824	753	682	611
1158	860	789	718	647
1193	895	824	753	682
1229	931	860	789	718
1264	966	895	824	753
1300	1002	931	860	789
1336	1038	967	896	825
1371	1073	1002	931	860
1407	1109	1038	967	896
1443	1145	1074	1003	932
1478	1180	1109	1038	967
1514	1216	1145	1074	1003
1550	1252	1181	1110	1039
1585	1287	1216	1145	1074
1621	1323	1252	1181	1110

Approximate module mass (kg)			
3804	3806	3808	3810
$(0.01563 \times L) + 4.26$	$(0.01563 \times L) + 5.23$	$(0.01563 \times L) + 6.21$	$(0.01563 \times L) + 7.19$
where L = Length in mm			

XB38 (on request)

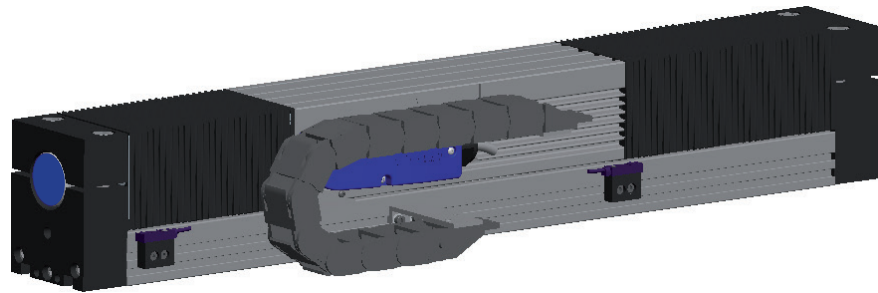

12

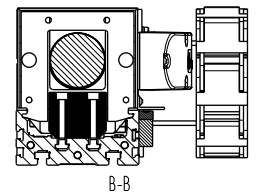
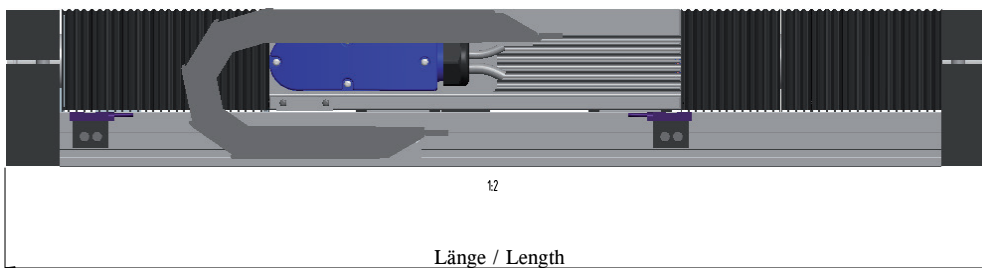

Length	Stroke			
	3804	3806	3808	3810
373	15	-	-	-
409	51	-	-	-
445	87	16	-	-
480	120	51	-	-
516	142	87	16	-
551	165	120	51	-
587	189	142	87	16
623	209	166	121	52
658	234	189	142	87
694	258	209	166	121
730	278	235	190	143
765	303	258	209	166
801	327	278	235	190
837	347	304	259	210
872	370	327	278	235
908	396	347	304	259
944	416	371	328	279
979	439	396	347	304

Length	Stroke			
	3804	3806	3808	3810
1015	463	416	371	328
1051	485	440	397	348
1086	508	463	416	371
1122	532	485	440	397
1158	552	509	464	417
1193	577	532	485	440
1229	601	552	509	464
1264	624	577	532	485
1300	646	601	552	509
1336	670	621	578	533
1371	693	646	601	552
1407	713	670	621	578
1443	739	690	647	602
1478	762	713	670	621
1514	782	739	690	647
1550	806	759	714	671
1585	831	782	739	690
1621	851	806	759	714

Approximate module mass (kg)			
3804	3806	3808	3810
$(0.01199 \times L) + 5.28$	$(0.01199 \times L) + 6.31$	$(0.01199 \times L) + 7.33$	$(0.01199 \times L) + 8.28$
where L = Length in mm			

FEEDBACK

The ServoTube Module is available with three feedback options with option S supplied as standard.

Option S feedback outputs analogue, differential sine and cosine signals for providing position feedback. Shown below are the relationships between forcer phase back EMF and position sensor outputs for one direction of motion (as shown by arrows). It should be noted that +SIN or -SIN is always in phase with forcer phase U. For the motion shown, -SIN is in phase with forcer phase U. For motion in the opposing direction +SIN is in phase with forcer phase U.

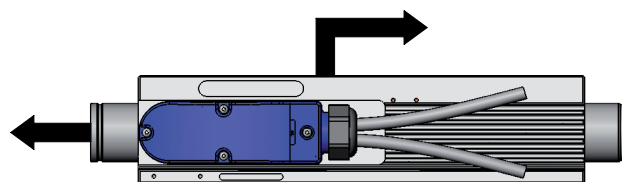
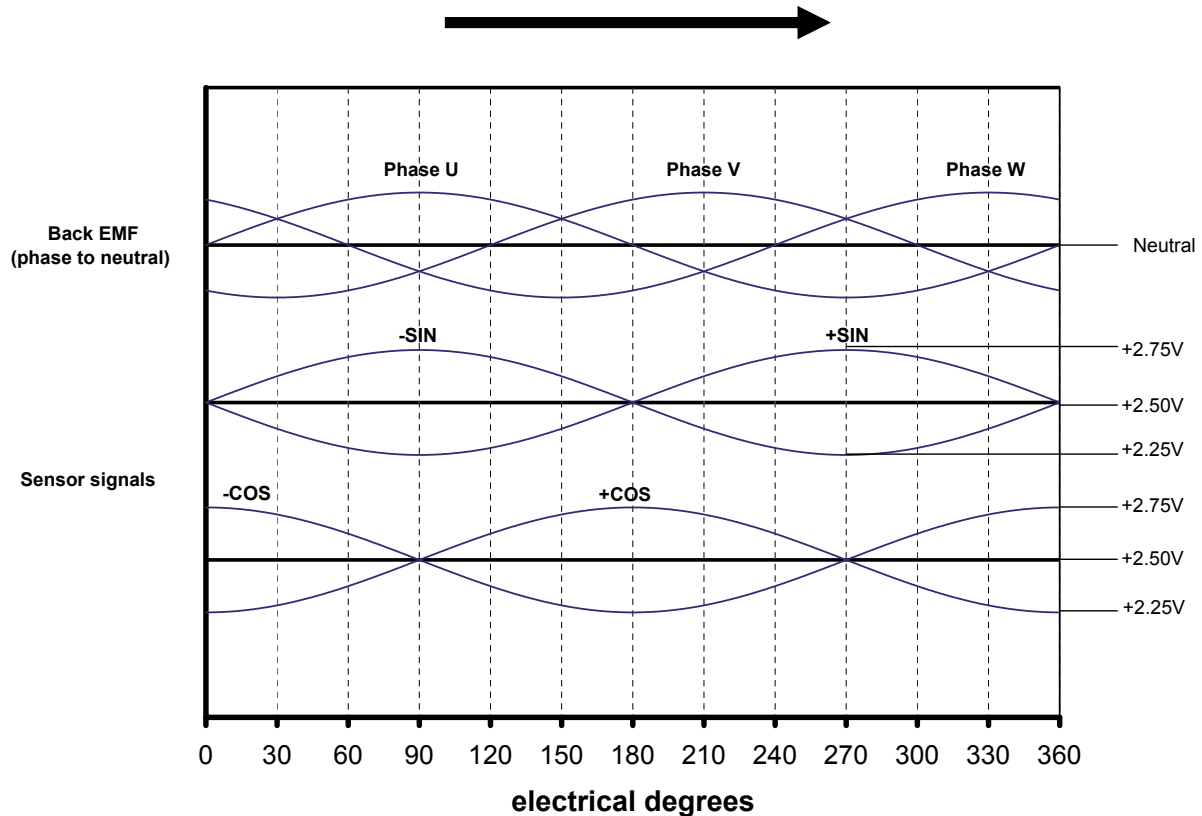

OPTION S SPECIFICATION	Xx38	units
Output signal period	71.2	mm
Signal amplitude (between +/- signals)	1	Vpk-pk
Output current	± 10	mA
Supply voltage	5 ± 0.25	Vd.c.
Supply current (output current=0)	15 ± 5	mA
Resolution ⁽¹⁾	20	μm
Position repeatability ⁽²⁾	± 20	μm
Absolute accuracy ⁽³⁾	± 400	μm

Notes: -

⁽¹⁾ Dependent on amplifier (indications with 12 bit resolution)

⁽²⁾ Dependent on amplifier. Under constant operating conditions. Self-heating of the forcer will cause expansion in the thrust rod during the initial warm up period. In high duty applications (corresponding to an internal forcer temperature of 80°C) a 1 metre thrust rod will expand typically by 250 μm .

⁽³⁾ Maximum error over 1 metre under constant operating conditions.

If improved positional accuracy is required, then in addition to option S, one external encoder option is available.

Option C uses the Renishaw RGH24X optical encoder. This option provides two channels, A and B, in phase quadrature (90° phase separated). A reference channel, Z, is also available that produces a single output at a position set by a reference mark.

SPECIFICATION	OPTION C	units
Signal output	EIA RS422A	-
Supply voltage	5 ± 0.25	Vd.c.
Supply current (output current=0)	120	mA
Supply current (outputs terminated with 120R)	195	mA
Resolution	1	µm
Position repeatability ⁽¹⁾	± 1	µm
Absolute accuracy ⁽²⁾	± 10	µm

Notes: -

⁽¹⁾ Dependent on amplifier. Under constant operating conditions.

⁽²⁾ Typical maximum error over 1 metre under constant operating conditions.

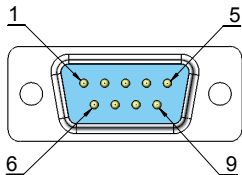

Connections are available via a 9-way D-sub male connector.

FUNCTION	+5Vd.c.	0V	A+	A-	B+	B-	Z+	Z-	Screen
PIN NUMBER	5	1	2	6	4	8	3	7	CASE

FORCER OVER-TEMPERATURE SENSOR



It is strongly recommended that the forcer over-temperature sensor is connected to the drive amplifier or servo controller **at all times** in order to reduce the risk of damage to the forcer due to excessive temperatures.

Protection is provided by three positive temperature coefficient (PTC) thermistors embedded in the forcer phases. As the forcer phase temperature approaches 100°C, the PTC thermistors exhibits a sharp increase in electrical resistance. This change in resistance can be detected by circuitry within the drive amplifier or servo controller and used to reduce or disable the output of the drive amplifier in order to protect the forcer.

SPECIFICATION	VALUE	units
Resistance in the temperature range -20°C to + 70°C	60 to 750	Ohms
Resistance at 85°C	≤1650	Ohms
Resistance at 95°C	≥3990	Ohms
Resistance at 105°C	≥12000	Ohms
Maximum continuous voltage	30	Vd.c.

FORCER ELECTRICAL CONNECTIONS

Connections are made within the termination box.

PIN NUMBER	FUNCTION
1	Phase U
2	Phase V
3	Phase W
Chassis	Earth/Screen

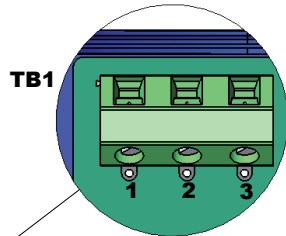

PIN NUMBER	FUNCTION
1	+SIN
2	-SIN
3	+COS
4	-COS
5	+5Vd.c.
6	0V
7	+TH (Thermistor)
8	-TH (Thermistor)

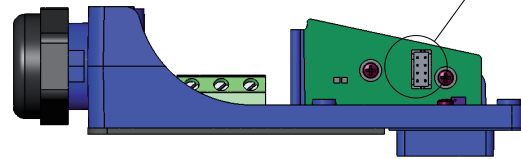
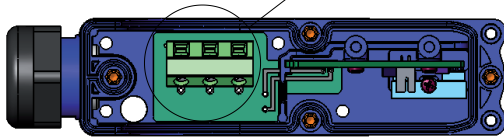
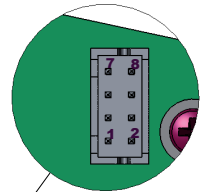

CABLE

The ServoTube Module has two separate cables providing connections for forcer power and position sensor. The cables are available in 3 metre, 5 metre and 10 m lengths.

SPECIFICATION	POWER	SENSOR
Overall diameter (nominal)	8.0mm	5.8mm
Outer jacket material	PUR	PUR
Number of conductors	4	4 x twisted pair
Size of conductors	1.5mm ² (16 AWG)	0.14mm ² (26 AWG)
Screened / Unscreened	Screened	Screened
Minimum bending radius - flexible routing	42mm	42mm
Operating temperature - flexible routing	-15°C to +80°C	-15°C to +80°C
Operating temperature - fixed routing	-30°C to +80°C	-30°C to +80°C

CABLE TERMINATION

The ServoTube Module cable is available with three termination options. **Option F** has the wire ends stripped and solder tinned ready for termination. All other options are terminated with connectors that plug directly into the desired amplifier. The connections for all options are shown below: -

SENSOR FUNCTION	D - (XTL-S)	N - (ESR-Pollmeier)	F - (Flying leads)
+SIN	14	6	Blue
-SIN	13	7	Red
+COS	12	11	White
-COS	11	12	Brown
+5Vd.c.	4	10	Yellow
0V	5	15	Green
+TH (Thermistor)	10	5	Pink
-TH (Thermistor)	15	15	Grey
SCREEN	1+ shell	Shell	SCREEN
Connector type	15-way high density D	15-way high density D	-
Amplifier connection	J8		-
POWER FUNCTION			
Forcer phase U	4	U	Black <u>1</u>
Forcer phase V	3	V	Black <u>2</u>
Forcer phase W	2	W	Black <u>3</u>
Earth (forcer body)	1	PE	Green/Yellow
SCREEN	1	Shell	SCREEN
Connector type	4-way 5mm pluggable terminal	4-way pluggable terminal	-
Amplifier connection	J2	X3	-

LIMITS



These limit switches are not intended as safety devices or as part of a system intended to ensure personal safety. When two switches are mounted in close proximity (as in the case of a left and right limit switch), a minimum of 30mm spacing between sense areas must be maintained.

If required, the ServoTube Module can be supplied with limit switches. There are two types available, NPN output and PNP output. Each output type is available with 5 metres of robotics cable. Each limit switch position is adjustable and switching is achieved by an actuator vane mounted on the forcer. Electrical connections are made via wire ends stripped and solder tinned ready for termination.

SPECIFICATION	VALUE			
	minimum	typical	maximum	units
Supply voltage	10	24	30	Vd.c.
Supply current	-	15	-	mA
Sink current	-	-	100	mA
"Closed" voltage	-	-	1	Vd.c.
Frequency response	-	-	600	Hz

The output for all types can be either a normally closed (NC, opener) or normally open (NO, closer) open collector transistor. A red indicator shows the output status.

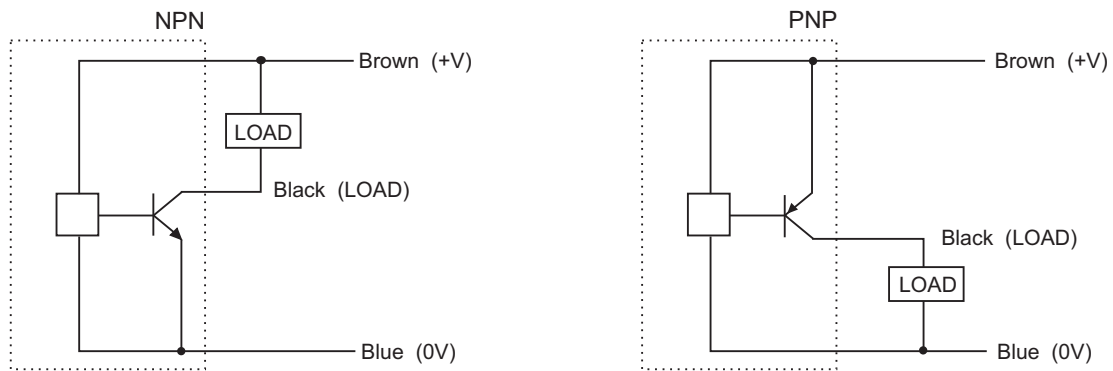

DRAG CHAIN

Size 15.3 is standard. Smaller drag chains on request.

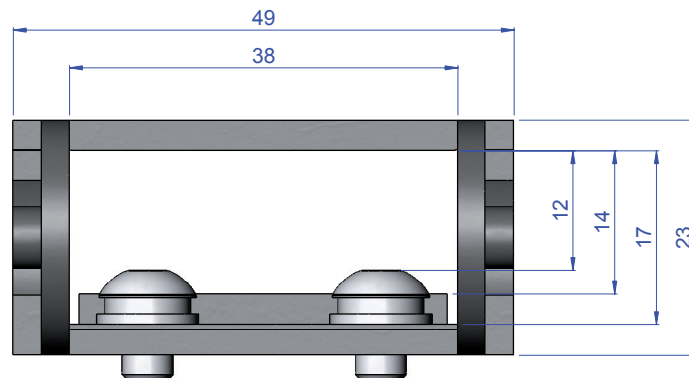

ENVIRONMENT

The ServoTube Module is intended for use in an environment within the following conditions: -

SPECIFICATION	VALUE
Operating temperature	0°C to +40°C
Storage temperature	-20°C to +70°C
Altitude (above mean sea level)	1000m
Overvoltage category	II
Pollution degree	2
EMC	light industrial

ORDER CODES

Module

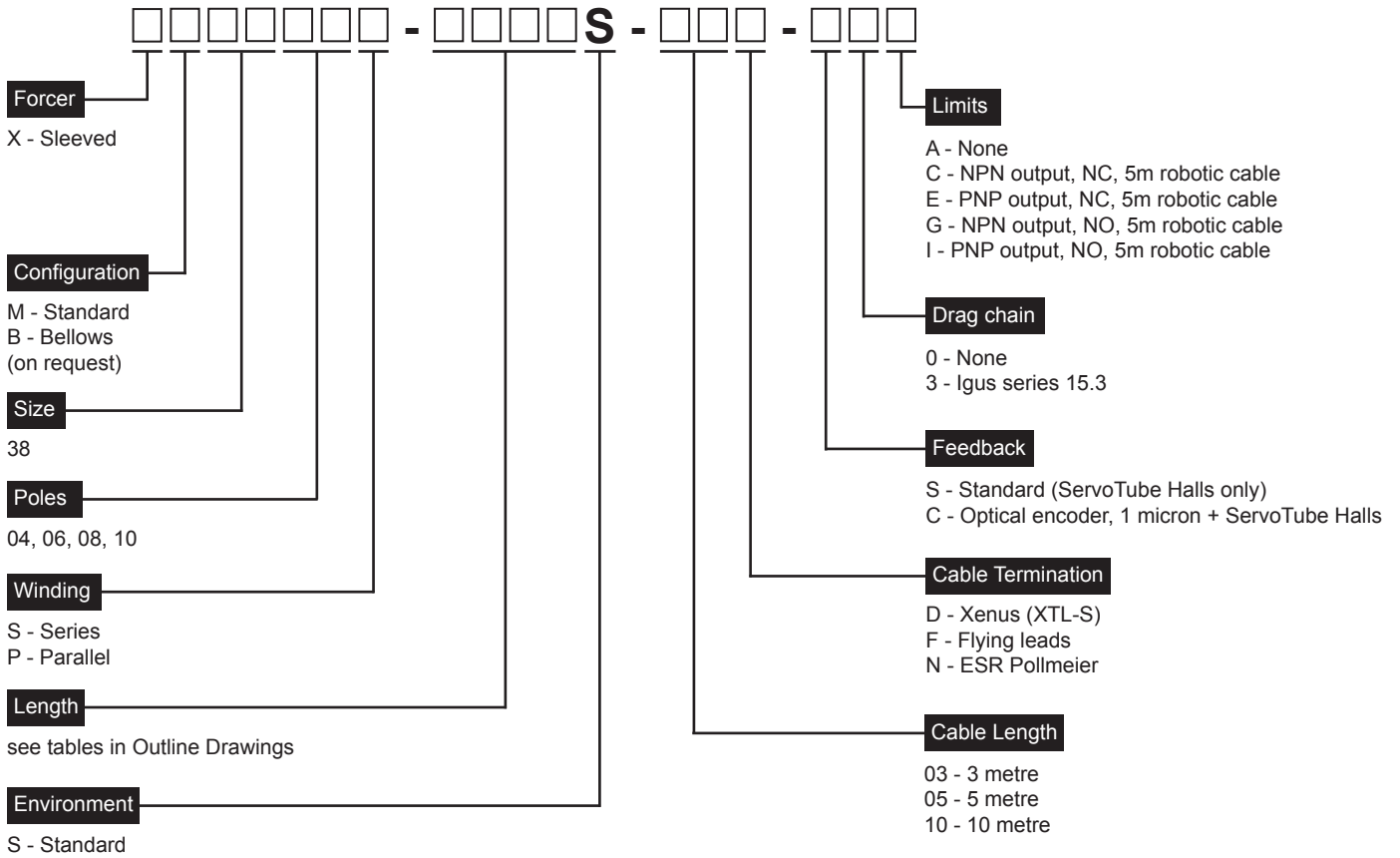

По вопросам продажи и поддержки обращайтесь:

Архангельск (8182)63-90-72
Астана +7(7172)727-132
Белгород (4722)40-23-64
Брянск (4832)59-03-52
Владивосток (423)249-28-31
Волгоград (844)278-03-48
Вологда (8172)26-41-59
Воронеж (473)204-51-73
Екатеринбург (343)384-55-89
Иваново (4932)77-34-06
Ижевск (3412)26-03-58
Казань (843)206-01-48

Калининград (4012)72-03-81
Калуга (4842)92-23-67
Кемерово (3842)65-04-62
Киров (8332)68-02-04
Краснодар (861)203-40-90
Красноярск (391)204-63-61
Курск (4712)77-13-04
Липецк (4742)52-20-81
Магнитогорск (3519)55-03-13
Москва (495)268-04-70
Мурманск (8152)59-64-93
Набережные Челны (8552)20-53-41

Нижний Новгород (831)429-08-12
Новокузнецк (3843)20-46-81
Новосибирск (383)227-86-73
Орел (4862)44-53-42
Оренбург (3532)37-68-04
Пенза (8412)22-31-16
Пермь (342)205-81-47
Ростов-на-Дону (863)308-18-15
Рязань (4912)46-61-64
Самара (846)206-03-16
Санкт-Петербург (812)309-46-40
Саратов (845)249-38-78

Смоленск (4812)29-41-54
Сочи (862)225-72-31
Ставрополь (8652)20-65-13
Тверь (4822)63-31-35
Томск (3822)98-41-53
Тула (4872)74-02-29
Тюмень (3452)66-21-18
Ульяновск (8422)24-23-59
Уфа (347)229-48-12
Челябинск (351)202-03-61
Череповец (8202)49-02-64
Ярославль (4852)69-52-93

Единый адрес для всех регионов: dre@nt-rt.ru || www.dunker.nt-rt.ru