



ЛИНЕЙНЫЕ ДВИГАТЕЛИ SM 11

Архангельск (8182)63-90-72
Астана +7(7172)727-132
Белгород (4722)40-23-64
Брянск (4832)59-03-52
Владивосток (423)249-28-31
Волгоград (844)278-03-48
Вологда (8172)26-41-59
Воронеж (473)204-51-73
Екатеринбург (343)384-55-89
Иваново (4932)77-34-06
Ижевск (3412)26-03-58
Казань (843)206-01-48

Калининград (4012)72-03-81
Калуга (4842)92-23-67
Кемерово (3842)65-04-62
Киров (8332)68-02-04
Краснодар (861)203-40-90
Красноярск (391)204-63-61
Курск (4712)77-13-04
Липецк (4742)52-20-81
Магнитогорск (3519)55-03-13
Москва (495)268-04-70
Мурманск (8152)59-64-93
Набережные Челны (8552)20-53-41

Нижний Новгород (831)429-08-12
Новокузнецк (3843)20-46-81
Новосибирск (383)227-86-73
Орел (4862)44-53-42
Оренбург (3532)37-68-04
Пенза (8412)22-31-16
Пермь (342)205-81-47
Ростов-на-Дону (863)308-18-15
Рязань (4912)46-61-64
Самара (846)206-03-16
Санкт-Петербург (812)309-46-40
Саратов (845)249-38-78

Смоленск (4812)29-41-54
Сочи (862)225-72-31
Ставрополь (8652)20-65-13
Тверь (4822)63-31-35
Томск (3822)98-41-53
Тула (4872)74-02-29
Тюмень (3452)66-21-18
Ульяновск (8422)24-23-59
Уфа (347)229-48-12
Челябинск (351)202-03-61
Череповец (8202)49-02-64
Ярославль (4852)69-52-93

Force

- » Peak: 46 - 92 N
- » Continuous: 6 - 27 N

Maximum Velocity

- » Up to 10.8 m/s

Feedback

- » Built-in position sensor
- » 1V pk-pk sin/cos
- » 6 micron repeatability
- » Optionally with high resolution encoder

Range of motion

- » Strokes up to 825 mm

Dimensions

- » W x H: 109 x 95mm
- » Rod diameter: 11mm

Applications

- » Packaging
- » Material Handling
- » Automated Assembly
- » Bio-medical

The OEM advantage

- » Easy integration
- » Flexible position control
- » High speed and acceleration
- » Clean, quiet operation
- » Low maintenance

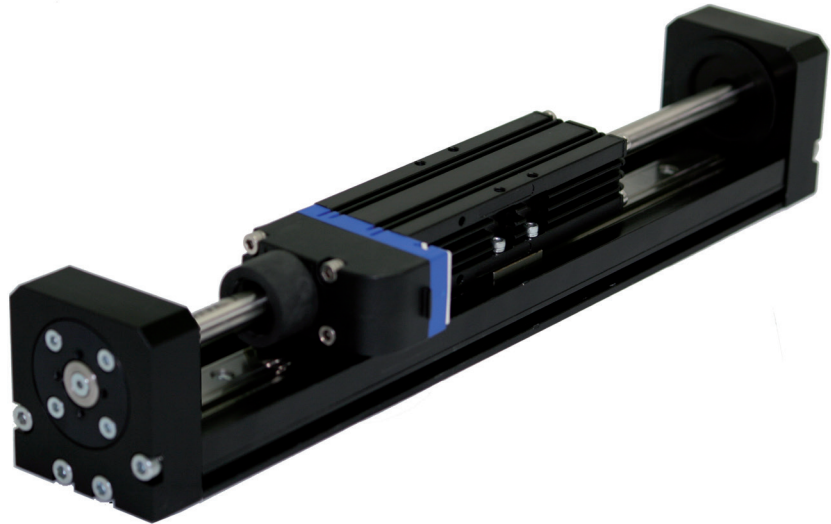

The ServoTube Module with fully integrated bearing rail and position encoder offers unprecedented value in high performance applications. The ServoTube Module is a cost effective alternative to ballscrew and belt drive systems where high speed and flexibility are required.

Four models deliver a continuous force of 6~27N (1,4~6lb) with peak forces of up to 92N (21lb). Standard stroke lengths of 28~825 mm are available.

The patented magnetic design of ServoTube generates 6 micron (0.24 mil) repeatability and 350 micron (14 mil) absolute accuracy, from a non-contact, integral position sensor. The standard ServoTube position encoder output is an industry standard 1V pk-pk sin/cos signal. For applications requiring higher levels of accuracy, the ServoTube Module is available with a fully integrated optical position encoder giving a resolution of 1 micron.

The non-contact nature of the direct linear drive results in life expectancy far above that for typical belt drive and ballscrew systems, with the added advantage of no deterioration in accuracy or repeatability over the entire life of the product.

The ServoTube Module is an ideal OEM solution for easy integration into pick-and-place gantry and general purpose material handling machines. The load is mounted directly to the forcer giving a very stable base. Servotube Modules can be easily integrated with each other or with other ServoTube products to create multi axis systems with minimal design effort.

The ServoTube has superior thermal efficiency, radiating heat uniformly. High duty cycles are possible without the need for forced-air or water cooling.

ELECTRICAL SPECIFICATIONS

FORCER TYPE	1104	1108	1112	1116	units
Peak force @ 25°C ambient for 1 sec	46.0	53.0	68.9	91.9	N
Peak current @ 25°C ambient for 1 sec	12	12	12	12	Apk
With 25 x 25 x2.5cm heatsink plate					
Continuous stall force @ 25°C ambient ⁽¹⁾	9.27	15.78	21.44	26.75	N
Continuous stall current @ 25°C ambient	1.71	2.52	2.64	2.47	Arms
	2.41	3.56	3.74	3.50	Apk
Without heatsink plate					
Continuous stall force @ 25°C ambient ⁽¹⁾	6.02	10.83	15.18	19.28	N
Continuous stall current @ 25°C ambient	1.11	1.73	1.87	1.78	Arms
	1.58	2.45	2.64	2.52	Apk
Force constant (sine commutation)	5.42	6.26	8.12	10.83	N/Arms
	3.83	4.42	5.74	7.66	N/Apk
Back EMF constant (phase to phase)	4.42	5.10	6.63	8.84	Vpk/m/s
Fundamental forcer constant	1.75	2.49	3.05	3.52	N/√W
Eddy current loss	0.14	0.25	0.36	0.47	N/m/s
Resistance @ 25°C (phase to phase)	4.90	3.27	3.68	4.91	Ohm
Resistance @ 100°C (phase to phase)	6.32	4.29	4.74	6.31	Ohm
Inductance @ 1kHz (phase to phase)	1.15	0.99	0.87	1.15	mH
Electrical time constant	0.23	0.23	0.23	0.23	ms
Maximum working voltage	75	75	75	75	V d.c.
Pole pitch (one electrical cycle)	25.6	25.6	25.6	25.6	mm
Peak acceleration ⁽²⁾	156	119	110	121	m/s ²
Maximum speed ⁽³⁾	10.8	9.5	7.9	8.2	m/s

Notes: -

⁽¹⁾ Reduce continuous stall force to 89% at 40°C ambient

⁽²⁾ Based on a moving forcer and no payload

⁽³⁾ Based on a moving forcer with triangular move over maximum stroke and no payload

THERMAL SPECIFICATIONS

FORCER TYPE	1104	1108	1112	1116	units
Maximum phase temperature	100	100	100	100	°C
Thermal resistance $R_{th_{phase-housing}}$	1.48	0.72	0.47	0.35	°C/Watt
With 25 x 25 x2.5cm heatsink plate					
Power dissipation @ 25°C ambient	27.6	40.1	49.7	58.0	Watt
Thermal resistance $R_{th_{housing-ambient}}$	1.24	1.15	1.04	0.94	°C/Watt
Without heatsink plate					
Power dissipation @ 25°C ambient	11.8	18.9	24.8	30.0	Watt
Thermal resistance $R_{th_{housing-ambient}}$	4.88	3.24	2.55	2.15	°C/Watt
Thermal time constant	142	176	202	223	s

MECHANICAL SPECIFICATIONS

FORCER TYPE	1104	1108	1112	1116	units
Maximum stroke	825	774	722	672	mm
Moving mass	0.293	0.443	0.626	0.756	kg
Maximum normal force, F_n ^{(1) (3)}	0.737		1.474		kN
Maximum side force, F_s ⁽¹⁾	5.2		10.4		Nm
Maximum roll moment, M_r ⁽¹⁾	2.9		123.6		Nm
Maximum pitch moment, M_p ⁽¹⁾	0.342		0.684		kN
Maximum yaw moment, M_y ⁽¹⁾	2.4		4.8		Nm
Maximum normal force, F_n ^{(2) (3)}	1.3		57.3		Nm
Maximum side force, F_s ⁽²⁾	60		80		$\mu\text{m/m}$
Maximum roll moment, M_r ⁽²⁾	80		100		$\mu\text{m/m}$
Maximum pitch moment, M_p ⁽²⁾	100		80		$\mu\text{m/m}$
Maximum yaw moment, M_y ⁽²⁾	80		80		$\mu\text{m/m}$
Constrained vertical straightness (flatness)	60		80		$\mu\text{m/m}$
Constrained horizontal straightness	80		100		$\mu\text{m/m}$
Unconstrained vertical straightness (flatness)	100		80		$\mu\text{m/m}$
Unconstrained horizontal straightness	80		80		$\mu\text{m/m}$

Notes: -

⁽¹⁾ For a bearing life expectancy of 10000 km with no other forces or moments

⁽²⁾ For a bearing life expectancy of 100000 km with no other forces or moments

⁽³⁾ Load in kg = force/9.81

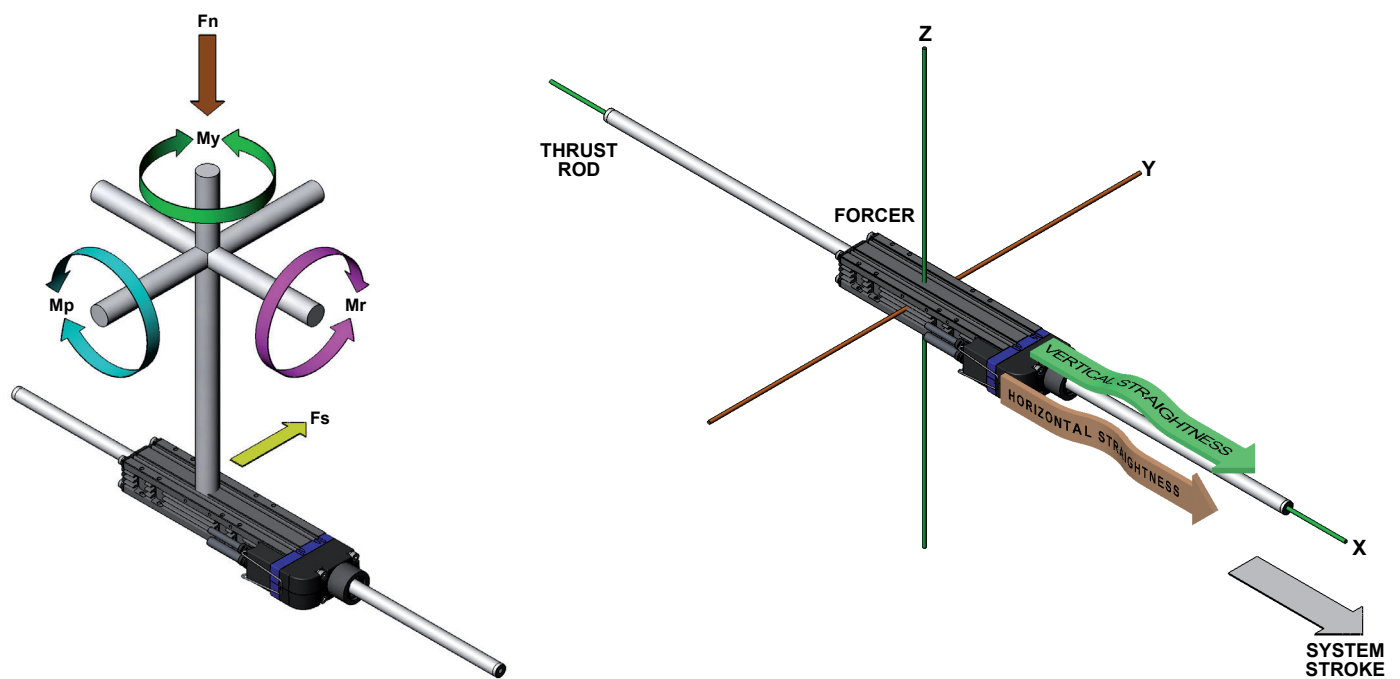

OUTLINE DRAWINGS

FORCER	LENGTH (mm)	WITH BUFFERS	APPROXIMATE MODULE MASS (kg)
1104	123.7	127.7	0.661 + (0.003251 x System Length In mm)
1108	174.9	178.9	0.758 + (0.003251 x System Length In mm)
1112	226.1	230.1	0.958 + (0.003251 x System Length In mm)
1116	277.0	281.0	1.086 + (0.003251 x System Length In mm)

CABLES:

1. Ø7.6 POWER CABLE
2. Ø5.8 SENSOR CABLE
3. Ø4.5 ENCODER CABLE (OPTIONAL)

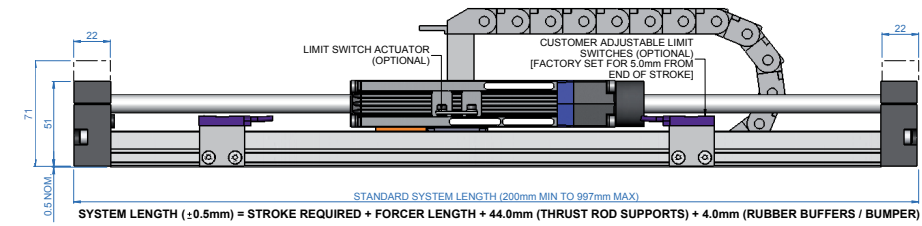
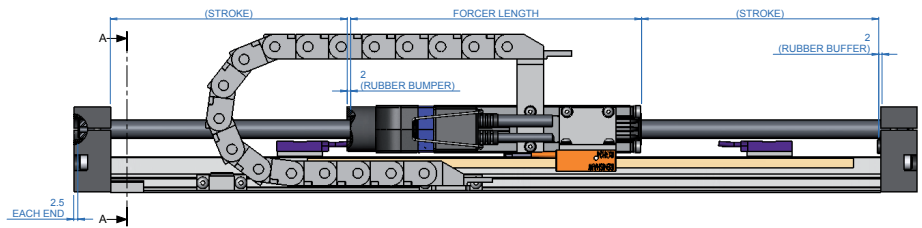
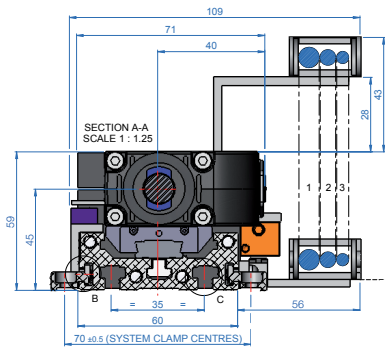
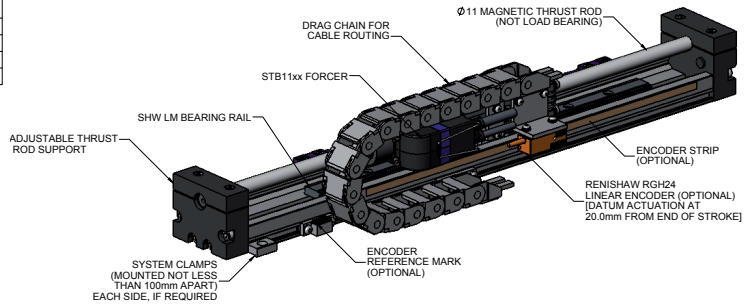

SYSTEM LENGTH (±0.5mm) = STROKE REQUIRED + FORCER LENGTH + 44.0mm (THRUST ROD SUPPORTS) + 4.0mm (RUBBER BUFFERS / BUMPER)

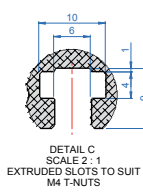
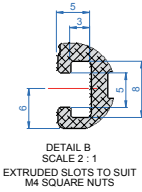

Length	Stroke			
	1104	1108	1112	1116
200	28	-	-	-
226	54	-	-	-
251	79	28	-	-
277	105	54	-	-
303	131	80	28	-
329	157	106	54	-
354	182	131	79	29
380	208	157	105	55
406	234	183	131	81
431	259	208	156	106
457	285	234	182	132
483	311	260	208	158
508	336	285	233	183
534	362	311	259	209
560	388	337	285	235
586	414	363	311	261

Length	Stroke			
	1104	1108	1112	1116
611	439	388	336	286
637	465	414	362	312
663	491	440	388	338
688	516	465	413	363
714	542	491	439	389
740	568	517	465	415
765	593	542	490	440
791	619	568	516	466
817	645	594	542	492
843	671	620	568	518
868	696	645	593	543
894	722	671	619	569
920	748	697	645	595
945	773	722	670	620
971	799	748	696	646
997	825	774	722	672

FEEDBACK

The ServoTube module is available with three feedback options with option S supplied as standard.

The position sensor outputs analogue, differential sine and cosine signals for providing position feedback. Shown below are the relationships between forcer phase back EMF and position sensor outputs for one direction of motion (as shown by arrows).

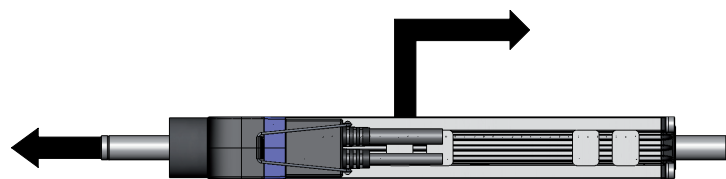
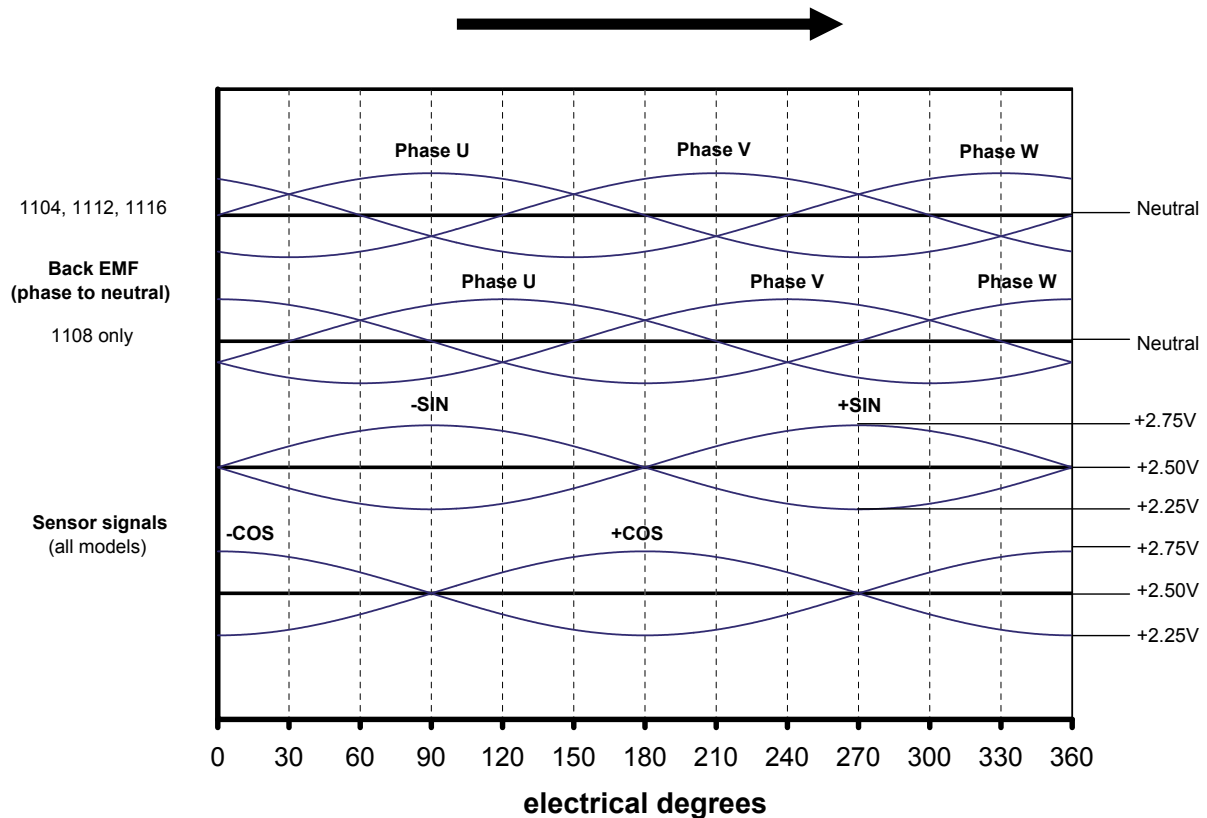

SPECIFICATION	VALUE	units
Output signal period	25.6	mm
Signal amplitude (between +/- signals)	1	Vpk-pk
Output current	± 10	mA
Supply voltage	5 ± 0.25	Vd.c.
Supply current (output current=0)	32 ± 5	mA
Resolution ⁽¹⁾	6	micron
Position repeatability ⁽²⁾	± 6	micron
Absolute accuracy ⁽³⁾	± 350	micron

Notes: -

⁽¹⁾ Dependent on amplifier (indication with 12 bit resolution)

⁽²⁾ Dependent on amplifier. Under constant operating conditions. Self-heating of the forcer will cause expansion in the thrust rod during the initial warm up period. In high duty applications (corresponding to an internal forcer temperature of 80°C) a 1 metre thrust rod will expand typically by 250 μm .

⁽³⁾ Maximum error over 1 metre under constant operating conditions.

If improved positional accuracy is required, then in addition to option S, one external encoder option is available.

Option C uses the Renishaw RGH24X optical encoder. This option provides two channels, A and B, in phase quadrature (90° phase separated). A reference channel, Z, is also available that produces a single output at a position set by a reference mark.

SPECIFICATION	OPTION C	units
Signal output	EIA RS422A	-
Supply voltage	5 ± 0.25	Vd.c.
Supply current (output current=0)	120	mA
Supply current (outputs terminated with 120R)	195	mA
Resolution	1	µm
Position repeatability ⁽¹⁾	± 1	µm
Absolute accuracy ⁽²⁾	± 10	µm

Notes: -

⁽¹⁾ Dependent on amplifier. Under constant operating conditions.

⁽²⁾ Typical maximum error over 1 metre under constant operating conditions.

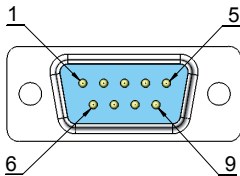

Connections are available via a 9-way D-sub male connector.

FUNCTION	+5Vd.c.	0V	A+	A-	B+	B-	Z+	Z-	Screen
PIN NUMBER	5	1	2	6	4	8	3	7	CASE

FORCER OVER-TEMPERATURE SENSOR



It is strongly recommended that the forcer over-temperature sensor is connected to the drive amplifier or servo controller **at all times** in order to reduce the risk of damage to the forcer due to excessive temperatures.

Protection is provided by a positive temperature coefficient (PTC) thermistor embedded in the forcer phases. As the forcer phase temperature approaches 100°C, the PTC thermistor exhibits a sharp increase in electrical resistance. This change in resistance can be detected by circuitry within the drive amplifier or servo controller and used to reduce or disable the output of the drive amplifier in order to protect the forcer.

SPECIFICATION	VALUE	units
Resistance at 25°C	235 to 705	Ohms
Resistance at 95°C	4700	Ohms
Resistance at 100°C	10000	Ohms
Maximum continuous voltage	32	Vd.c.

FORCER ELECTRICAL CONNECTIONS

Connections on the forcer are available via a 15-way high density D-sub male connector. Connections are as follows: -

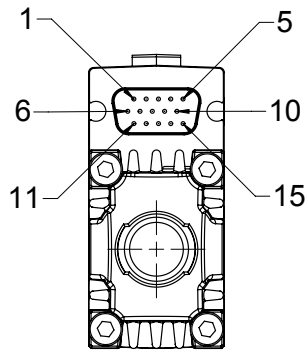

* Pins 6,9 and 10 must be connected together in user cable connector.

PIN NUMBER	FUNCTION
1	+SIN
2	-SIN
3	+COS
4	-COS
5	+5Vd.c.
6*	0V
7	+TH (Thermistor)
8	-TH (Thermistor)
9*	Factory use only
10*	Factory use only
11	No connection
12	Earth (forcer body)
13	Forcer phase U
14	Forcer phase V
15	Forcer phase W
Connector body	SCREEN

CABLE

The ServoTube Module has a cable assembly that comprises power and sensor cables with a 15 way high density D-sub female connector for direct connection to the forcer. The cables are available in 3 metre or 5 metre lengths.

	POWER	SENSOR
Overall diameter (nominal)	4.7mm	5.8mm
Outer jacket material	PUR	PUR
Number of conductors	4	4 x twisted pair
Size of conductors	0.34mm ² (22 AWG)	0.14mm ² (26AWG)
Screened / Unscreened	Screened	Screened
Minimum bending radius - flexible routing	44mm	44mm
Operating temperature - flexible routing	-40°C to +90°C	-40°C to +90°C
Operating temperature - fixed routing	-50°C to +90°C	-50°C to +90°C

CABLE TERMINATION

The ServoTube Module cable is available with two termination options. **Option F** has the wire ends stripped and solder tinned ready for termination. **Option C** is terminated with connectors that plug directly into a Accelnet Micro Panel amplifier (ACJ-S). The connections for both options are shown below:

SENSOR FUNCTION	F-FLYING LEADS	C-ACCELNET MICRO PANEL
+SIN	Blue	8
-SIN	Red	1
+COS	White	9
-COS	Brown	2
+5Vd.c.	Yellow	4
0V	Green	11
+TH (Thermistor)	Pink	7
-TH (Thermistor)	Grey	6
SCREEN	SCREEN	14
Connector type	-	Samtec IPD1-07-D
Amplifier connection	-	J4
POWER FUNCTION		
Forcer phase U	Yellow	4
Forcer phase V	White	3
Forcer phase W	Brown	2
Earth (forcer body)	Green	1
SCREEN	SCREEN	1
Connector type	-	Molex 39-01-4051
Amplifier connection	-	J2

LIMITS



These limit switches are not intended as safety devices or as part of a system intended to ensure personal safety. When two switches are mounted in close proximity (as in the case of a left and right limit switch), a minimum of 30mm spacing between sense areas must be maintained.

If required, the ServoTube Module can be supplied with limit switches. There are two types available, NPN output and PNP output. Each output type is available with a 5 m robotics cable. Each limit switch position is adjustable and switching is achieved by an actuator vane mounted on the forcer. Electrical connections are made via wire ends stripped and solder tinned ready for termination.

SPECIFICATION	VALUE			
	minimum	typical	maximum	units
Supply voltage	10	24	30	Vd.c.
Supply current	-	15	-	mA
Sink current	-	-	100	mA
"Closed" voltage	-	-	1	Vd.c.
Frequency response	-	-	600	Hz

The output for all types can be either a normally closed (NC, opener) or normally open (NO, closer) open collector transistor. A red indicator shows the output status.

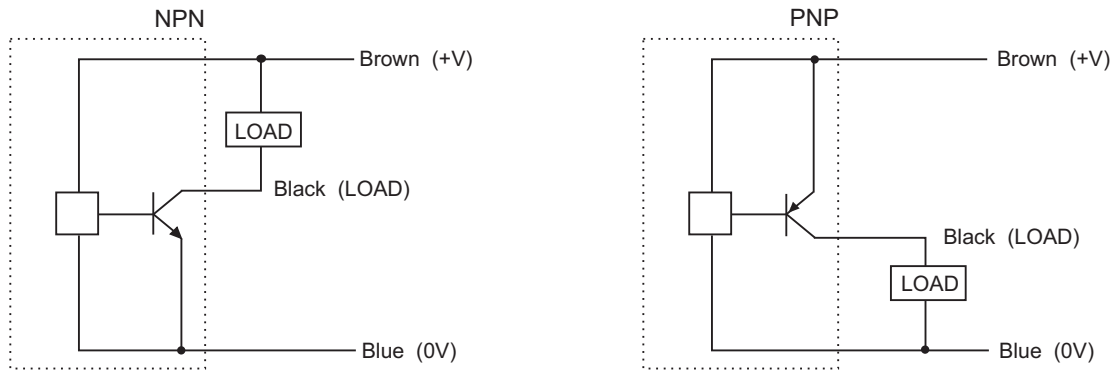

DRAG CHAIN

Igus size 07.3 is standard. Smaller drag chain is available on request.

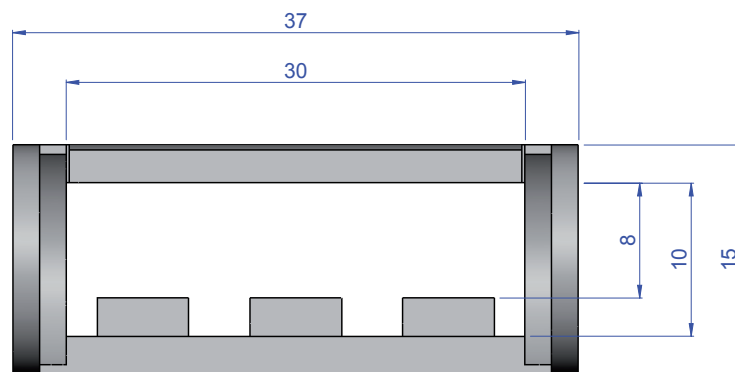

Option 3

ENVIRONMENT

The ServoTube Module is intended for use in an environment within the following conditions: -

SPECIFICATION	VALUE
Operating temperature	0°C to +40°C
Storage temperature	-25°C to +70°C
Altitude (above mean sea level)	1000m
Overvoltage category	II
Pollution degree	2
EMC	light industrial

ORDER CODES

Module

SM1 1 - **S** - -

Poles

04, 08, 12, 16

Length

see tables in Outline Drawings

Environment

S - Standard

Cable Length

03 - 3 metre
05 - 5 metre

Cable Termination

C - Accelnet Micro Panel (ACJ-S)
F - Flying leads

Limits

A - None
C - NPN output, NC, 5m robotic cable
E - PNP output, NC, 5m robotic cable
G - NPN output, NO, 5m robotic cable
I - PNP output, NO, 5m robotic cable

Drag chain

0 - None
3 - Igus series 07.3

Feedback

S - Standard (ServoTube Halls only)
C - Optical encoder, 1 micron + ServoTube Halls

По вопросам продажи и поддержки обращайтесь:

Архангельск (8182)63-90-72
Астана +7(7172)727-132
Белгород (4722)40-23-64
Брянск (4832)59-03-52
Владивосток (423)249-28-31
Волгоград (844)278-03-48
Вологда (8172)26-41-59
Воронеж (473)204-51-73
Екатеринбург (343)384-55-89
Иваново (4932)77-34-06
Ижевск (3412)26-03-58
Казань (843)206-01-48

Калининград (4012)72-03-81
Калуга (4842)92-23-67
Кемерово (3842)65-04-62
Киров (8332)68-02-04
Краснодар (861)203-40-90
Красноярск (391)204-63-61
Курск (4712)77-13-04
Липецк (4742)52-20-81
Магнитогорск (3519)55-03-13
Москва (495)268-04-70
Мурманск (8152)59-64-93
Набережные Челны (8552)20-53-41

Нижний Новгород (831)429-08-12
Новокузнецк (3843)20-46-81
Новосибирск (383)227-86-73
Орел (4862)44-53-42
Оренбург (3532)37-68-04
Пенза (8412)22-31-16
Пермь (342)205-81-47
Ростов-на-Дону (863)308-18-15
Рязань (4912)46-61-64
Самара (846)206-03-16
Санкт-Петербург (812)309-46-40
Саратов (845)249-38-78

Смоленск (4812)29-41-54
Сочи (862)225-72-31
Ставрополь (8652)20-65-13
Тверь (4822)63-31-35
Томск (3822)98-41-53
Тула (4872)74-02-29
Тюмень (3452)66-21-18
Ульяновск (8422)24-23-59
Уфа (347)229-48-12
Челябинск (351)202-03-61
Череповец (8202)49-02-64
Ярославль (4852)69-52-93

Единый адрес для всех регионов: dre@nt-rt.ru || www.dunker.nt-rt.ru